

ISSN 2531-2960

Volume 9, Issue 22 -- e2025922 January -- December - 2025

Journal of Technological Development

ECORFAN®

ECORFAN-Spain

Chief Editor

Banerjee, Bidisha. PhD

Executive Director

Ramos-Escamilla, María. PhD

Editorial Director

Peralta-Castro, Enrique. MsC

Web Designer

Escamilla-Bouchan, Imelda. PhD

Web Diagrammer

Luna-Soto, Vladimir. PhD

Editorial Assistant

Soriano-Velasco, Jesús. BsC

Philologist

Ramos-Arancibia, Alejandra. BsC

Journal of Technological Development

Volume 9, Number 22: e2025922 January – December 2025, is a Continuous publication - Journal edited by ECORFAN-Spain. 38 Matacerquillas street, Postcode: 28411. Moralarzal – Madrid WEB: www.ecorfan.org/spain, journal@ecorfan.org. Editor in Chief: Banerjee, Bidisha. PhD, ISSN On line: 2531-2960. Responsible for the latest update of this number ECORFAN Computer Unit. Escamilla-Bouchán, Imelda. PhD, Luna-Soto, Vladimir. PhD, 38 Matacerquillas street, Postcode: 28411. Moralarzal –Madrid, last updated December 30, 2025.

The opinions expressed by the authors do not necessarily reflect the views of the editor of the publication.

It is strictly forbidden to reproduce any part of the contents and images of the publication without permission of the National Institute of Copyright

Journal of Technological Development

Definition of Research Journal

Scientific Objectives

Support the international scientific community in its written production Science, Technology and Innovation in the Field of Engineering and Technology in Subdisciplines of technological development, digital technology, technological impact, teaching with computer help, reliability of computers, heuristics, computing, machine arithmetic instructions, artificial intelligence, algorithmic languages, programming languages

ECORFAN-Mexico SC is a Scientific and Technological Company in contribution to the Human Resource training focused on the continuity in the critical analysis of International Research and is attached to SECIHTI-RENIICYT number 1702902, its commitment is to disseminate research and contributions of the International Scientific Community, academic institutions, agencies and entities of the public and private sectors and contribute to the linking of researchers who carry out scientific activities, technological developments and training of specialized human resources with governments, companies and social organizations.





Encourage the interlocution of the International Scientific Community with other Study Centers in Mexico and abroad and promote a wide incorporation of academics, specialists and researchers to the publication in Science Structures of Autonomous Universities - State Public Universities - Federal IES - Polytechnic Universities - Technological Universities - Federal Technological Institutes - Normal Schools - Decentralized Technological Institutes - Intercultural Universities - S & T Councils - SECIHTI Research Centers.

Scope, Coverage and Audience





Journal of Technological Development is a Research Journal edited by ECORFAN-Mexico S.C in its Holding with repository in Spain, is a scientific publication arbitrated and indexed with semester periods. It supports a wide range of contents that are evaluated by academic peers by the Double-Blind method, around subjects related to the theory and practice of technological development, digital technology, technological impact, teaching with computer help, reliability of computers, heuristics, computing, machine arithmetic instructions, artificial intelligence, algorithmic languages, programming languages with diverse approaches and perspectives, that contribute to the diffusion of the development of Science Technology and Innovation that allow the arguments related to the decision making and influence in the formulation of international policies in the Field of Engineering and Technology. The editorial horizon of ECORFAN-Mexico® extends beyond the academy and integrates other segments of research and analysis outside the scope, as long as they meet the requirements of rigorous argumentative and scientific, as well as addressing issues of general and current interest of the International Scientific Society.

Editorial Board

Castillo - López, Oscar. PhD

 Academia de Ciencias de Polonia •  I-5578-2019 •  0000-0002-7385-5689 •  21473

Herrera - Diaz, Israel Enrique. PhD

 Center of Research in Mathematics •  KHC-5238-2024 •  0000-0002-2117-7548 •  207880

Ayala - García, Ivo Nefthalí. PhD

 University of Southampton •  0000-0001-5144-4224 •  220437

Dector - Espinoza, Andrés. PhD

 Centro de Microelectrónica de Barcelona •  0000-0001-6265-0891 •  335634





Nazario - Bautista, Elivar. PhD

 Centro de Investigacion en óptica y nanofisica •  0000-0002-9556-2748 •  34699





Mayorga - Ortiz, Pedro. PhD

 Institut National Polytechnique de Grenoble •  0000-0002-1889-6154





Cercado - Quezada, Bibiana. PhD

 Intitut National Polytechnique Toulouse •  M-6312-2013 •  0000-0003-4760-5114 •  90675





Carbajal - De La Torre, Georgina. PhD

 Université des Sciences et Technologies de Lille •  AFE-9122-2022 •  0000-0001-6315-0952 •  31563

Hernandez - Escobedo, Quetzalcoatl Cruz. PhD



 Universidad Central del Ecuador •  P-2638-2019 •  0000-0002-2981-7036 •  220140

Fernandez - Zayas, José Luis. PhD





 University of Bristol •  AAJ-5625-2021 •  0000-0002-9914-6709 •  1568

Arbitration Committee

González - Reyna, Sheila Esmeralda. PhD

 Instituto Tecnológico Superior de Irapuato •  0000-0002-2158-7248 •  329483

Palma, Oscar. PhD

 Instituto Tecnológico de Conkal •  P-5389-2018 •  0000-0001-6767-741X •  585006

Cortez - González, Joaquín. PhD

 Instituto Tecnológico de Sonora •  JMR-2822-2023 •  0000-0003-3900-5880





Baeza - Serrato, Roberto. PhD

 Universidad de Guanajuato •  0000-0003-4454-0845 •  274593





Arroyo - Figueroa, Gabriela. PhD

 Universidad de Guanajuato •  0000-0002-4187-4367 •  57295





González - López, Samuel. PhD

 Universidad Tecnológica de Nogales •  N-6460-2018 •  0000-0002-1511-1227 •  345102





Castañón - Puga, Manuel. PhD

 Universidad Autónoma de Baja California •  B-2842-2013 •  0000-0003-2890-512X •  175505

Arredondo - Soto, Karina Cecilia. PhD

 Universidad Autónoma de Baja California •  F-4074-2019 •  0000-0002-8929-7319 •  527663





Bautista - Santos, Horacio. PhD

 Instituto Tecnológico Superior de Tantoyuca •  R-1375-2017 •  0000-0002-3925-2438 •  200275

Cruz - Barragán, Aidee. PhD

 Universidad de la Sierra Sur •  0000-0002-8305-9897 •  671712

Castillo - Topete, Víctor Hugo. PhD

 Universidad de Colima •  HJH-9311-2023 •  0000-0001-9569-9595 •  170663

Assignment of Rights

The sending of an Article to Journal of Technological Development emanates the commitment of the author not to submit it simultaneously to the consideration of other series publications for it must complement the Originality Format for its Article.

The authors sign the Authorization Format for their Article to be disseminated by means that ECORFAN-Mexico, S.C. In its Holding Spain considers pertinent for disclosure and diffusion of its Article its Rights of Work.

Declaration of Authorship

Indicate the Name of Author and Coauthors at most in the participation of the Article and indicate in extensive the Institutional Affiliation indicating the Department.

Identify the Name of Author and Coauthors at most with the CVU Scholarship Number-PNPC or SNI-SECIHTI- Indicating the Researcher Level and their Google Scholar Profile to verify their Citation Level and H index.

Identify the Name of Author and Coauthors at most in the Science and Technology Profiles widely accepted by the International Scientific Community ORC ID - Researcher ID Thomson - arXiv Author ID - PubMed Author ID - Open ID respectively.

Indicate the contact for correspondence to the Author (Mail and Telephone) and indicate the Researcher who contributes as the first Author of the Article.

Plagiarism Detection

All Articles will be tested by plagiarism software PLAGSCAN if a plagiarism level is detected Positive will not be sent to arbitration and will be rescinded of the reception of the Article notifying the Authors responsible, claiming that academic plagiarism is criminalized in the Penal Code.

Arbitration Process

All Articles will be evaluated by academic peers by the Double Blind method, the Arbitration Approval is a requirement for the Editorial Board to make a final decision that will be final in all cases. MARVID® is a derivative brand of ECORFAN® specialized in providing the expert evaluators all of them with Doctorate degree and distinction of International Researchers in the respective Councils of Science and Technology the counterpart of SECIHTI for the chapters of America-Europe-Asia- Africa and Oceania. The identification of the authorship should only appear on a first removable page, in order to ensure that the Arbitration process is anonymous and covers the following stages: Identification of the Research Journal with its author occupation rate - Identification of Authors and Coauthors - Detection of plagiarism PLAGSCAN - Review of Formats of Authorization and Originality-Allocation to the Editorial Board-Allocation of the pair of Expert Arbitrators-Notification of Arbitration -Declaration of observations to the Author-Verification of Article Modified for Editing-Publication.

Instructions for Scientific, Technological and Innovation Publication

Knowledge Area

The works must be unpublished and refer to topics of technological development, digital technology, technological impact, teaching with computer help, reliability of computers, heuristics, computing, machine arithmetic instructions, artificial intelligence, algorithmic languages, programming languages and other topics related to Engineering and Technology.

Presentation of the Content

In the first chapter we present *Spatial and temporal variation of BTEX in Villahermosa, Tabasco, during the dry and rainy seasons of 2024* by Uc-Chi, Martha Patricia, Cerón-Bretón, Julia Griselda, Cerón-Bretón, Rosa María and Silis-Esquivel, Jhoanna, with adscription in the Universidad Autónoma del Carmen, as the following article we present *Metallic particulates in pulmonary tissue* by Peña-García, Laura Elizabeth, with adscription in the Universidad de Guadalajara, as the following article we present *Learning analytics with CAD traces and predictive models: Reliability and performance* by Corral-Verdugo, Alex, Sepúlveda-Romo, Adrián, Jimenez-Lopez, Eusebio and León-Rochin, German, with adscription in the Universidad Tecnológica del sur de Sonora and Instituto Tecnológico Superior de Cajeme, as the following article we present *Environmental impact of wastewater discharges containing surfactants and their effect on biomass in anaerobic reactors during treatment* by Terreros, Jesús, Velazquez, Gisela and Muriel, Frank, with adscription in the Universidad Tecnológica del Valle de Toluca, as the following article we present *Perception of electricity service quality and its impact on local development. Study in Jalpan de Serra, Querétaro* by Morado-Huerta, Ma Guadalupe, Márquez-Hernández, Olga, López-Hernández, Edgardo and Ibarra-Pérez, Juan, with adscription in the Universidad Tecnológica de San Juan del Río, as the following article we present *Design and selection of solid urban waste collection routes using mixed integer linear programming under a practical approach* by Velarde-Cantú, José Manuel, López-Acosta, Mauricio, Chacara-Montes, Allán and Ramírez-Cardenas, Ernesto, with adscription in the Instituto Tecnológico de Sonora, as the last article we present *Design and CAD modeling of the mechanical base of an anthropomorphic robot arm, integrating technical analysis, 2D/3D drawing, assembly and animation, for educational purposes* by Peña-Montes De Oca, Adriana Isela, Gallardo-De La Rocha, Alfonso and Hernández, Adriana Janette, with adscription in the Universidad Tecnológica de Jalisco.

Contet

Artículo	Page
Spatial and temporal variation of BTEX in Villahermosa, Tabasco, during the dry and rainy seasons of 2024 Uc-Chi, Martha Patricia, Cerón-Bretón, Julia Griselda, Cerón-Bretón, Rosa María and Silis-Esquivel, Jhoanna <i>Universidad Autónoma del Carmen</i>	1-12
Metallic particulates in pulmonary tissue Peña-García, Laura Elizabeth <i>Universidad de Guadalajara</i>	1-9
Learning analytics with CAD traces and predictive models: Reliability and performance Corral-Verdugo, Alex, Sepúlveda-Romo, Adrián, Jimenez-Lopez, Eusebio and León-Rochin, German <i>Universidad Tecnológica del sur de Sonora</i> <i>Instituto Tecnológico Superior de Cajeme</i>	1-13
Environmental impact of wastewater discharges containing surfactants and their effect on biomass in anaerobic reactors during treatment Terreros, Jesús, Velazquez, Gisela and Muriel, Frank <i>Universidad Tecnológica del Valle de Toluca</i>	1-16
Perception of electricity service quality and its impact on local development. Study in Jalpan de Serra, Querétaro Morado-Huerta, Ma Guadalupe, Márquez-Hernández, Olga, López-Hernández, Edgardo and Ibarra-Pérez, Juan <i>Universidad Tecnológica de San Juan del Río</i>	1-11
Design and selection of solid urban waste collection routes using mixed integer linear programming under a practical approach Velarde-Cantú, José Manuel, López-Acosta, Mauricio, Chacara-Montes, Allán and Ramírez-Cardenas, Ernesto <i>Instituto Tecnológico de Sonora</i>	1-7
Design and CAD modeling of the mechanical base of an anthropomorphic robot arm, integrating technical analysis, 2D/3D drawing, assembly and animation, for educational purposes Peña-Montes De Oca, Adriana Isela, Gallardo-De La Rocha, Alfonso and Hernández, Adriana Janette <i>Universidad Tecnológica de Jalisco</i>	1-8

Spatial and temporal variation of BTEX in Villahermosa, Tabasco, during the dry and rainy seasons of 2024

Variación espacial y temporal de BTEX en Villahermosa, Tabasco, en épocas seca y lluviosa de 2024

Uc-Chi, Martha Patricia^{*a}, Cerón-Bretón, Julia Griselda^b, Cerón-Bretón, Rosa María^c and Silis-Esquivel, Jhoanna^d

^a Universidad Autónoma del Carmen • LFV-4391-2024 • 0000-0002-9480-6034 • 187081

^b Universidad Autónoma del Carmen • LFV-2975-2024 • 0000-0003-1551-7988 • 122903

^c Universidad Autónoma del Carmen • LFV-4405-2024 • 0000-0001-8647-022X • 30106

^d Universidad Autónoma del Carmen • LFV-2975-2024 • 0000-0003-1551-7988 • 122903

Classification:

Area: Physics, Mathematics and Earth Sciences

Field: Earth and Space Sciences

Discipline: Atmospheric Sciences

Subdiscipline: Atmospheric Pollution

<https://doi.org/10.35429/JTD.2025.9.22.1.1.12>

History of the article:

Received: January 13, 2025

Accepted: November 10, 2025

* [muc.unacar.mx@pampano]



Abstract

BTEX are common volatile organic compounds in urban air that, at high concentrations, can affect the health of the exposed population. In Mexico there are no regulatory limits or continuous monitoring for these compounds. In this study, BTEX concentrations were evaluated by passive sampling at five sites in Tabasco and their health risk during the dry and rainy seasons of 2024. Eighty samples were collected and analyzed by gas chromatography with a flame ionization detector (FID). The relative abundance was $B < X < E < T$ in the dry season and $B < X < T < E$ in the rainy season. The BTEX ratios suggest recent emissions from vehicle traffic. The results show that all sites exceed the US EPA reference risk level (1×10^{-6}), except for the Airport site in the dry season and the football school in the rainy season, with children being the most vulnerable.

Resumen

Los BTEX son compuestos orgánicos volátiles comunes en el aire urbano que, en altas concentraciones, pueden afectar la salud de la población expuesta. En México no existen límites normativos ni monitoreo continuo para estos compuestos. En este estudio se evaluaron las concentraciones de BTEX mediante muestreo pasivo en cinco sitios de Tabasco y su riesgo a la salud durante las temporadas seca y lluviosa de 2024. Se recolectaron 80 muestras analizadas por cromatografía de gases con detector FID. La abundancia relativa fue $B < X < E < T$ en secas y $B < X < T < E$ en lluvias. Las razones BTEX sugieren emisiones recientes por tráfico vehicular. Los resultados muestran que todos los sitios superan el nivel de riesgo de referencia de la US EPA (1×10^{-6}), excepto los sitios Aeropuerto en secas y la escuela de fútbol en lluvias, siendo los niños los más vulnerables.

Spatial and temporal variation of BTEX in Villahermosa, Tabasco, during the dry and rainy seasons of 2024		
Objectives	Methodology	Contribution
Determine BTEX concentrations.	Sampling by passive method using Radiello®.	Report on the spatio-temporal distribution of BTEX in Tabasco.
Analyze by gas chromatography.	Obtain chromatograms by GC-FID.	Establishing relationships between meteorology and BTEX
Estimate the carcinogenic risk and non-carcinogenic risk of BTEX.	Statistical Analysis	Scientific basis for future research on air quality.

BTEX, Passive Sampling, Gas Chromatography

Variación espacial y temporal de BTEX en Villahermosa, Tabasco, en épocas seca y lluviosa de 2024		
Objetivos	Metodología	Contribución
Determinar la concentración de BTEX.	Muestreo de BTEX por método pasivo utilizando Radiello®.	Informar sobre la distribución espacio-temporal de BTEX en Tabasco.
Analizar por cromatografía de gases.	Obtener cromatogramas por GC-FID.	Establecer relaciones entre la meteorología y BTEX
Estimar el riesgo carcinogénico y el riesgo no carcinogénico de BTEX.	Análisis estadístico.	Base científica para futuras investigaciones sobre calidad del aire.

BTEX, muestreo pasivo, Cromatografía de gases

Area: Strengthening the scientific community

Citation: Uc-Chi, Martha Patricia, Cerón-Bretón, Julia Griselda, Cerón-Bretón, Rosa María and Silis-Esquivel, Jhoanna. [2025]. Spatial and temporal variation of BTEX in Villahermosa, Tabasco, during the dry and rainy seasons of 2024. Journal of Technological Development. 9[22] 1-12: e10922112



ISSN 2531-2960/© 2009 The Authors. Published by ECORFAN-México, S.C. for its Holding Spain on behalf of Journal of Technological Development. This is an open-access article under the license CC BY-NC-ND license [<http://creativecommons.org/licenses/by-nc-nd/4.0/>]

Peer review under the responsibility of the Scientific Committee MARVID® in the contribution to the scientific, technological and innovation Peer Review Process through the training of Human Resources for the continuity in the Critical Analysis of International Research.



Registro Nacional de Instituciones y Empresas Científicas y Tecnológicas

1702902 SECIHTI

Introduction

Air, a vital resource for life, has been rapidly degraded by toxic pollutants due to social, economic, and industrial development. According to the (PAHO, 2014), 99% of the population is exposed to air pollution, which causes at least 4.2 million deaths worldwide each year. Air pollution generates high economic costs for health, the environment and productivity (Briz-Redón *et al.*, 2021). In Mexico, in 2023, atmospheric emissions represented an expenditure of 809,443.1 million pesos, equivalent to 2.5% of GDP (INEGI, 2024).

Among the known atmospheric pollutants are volatile organic compounds (VOCs), which are gases emitted by various sources that act as precursors to tropospheric ozone, some of which are toxic. The VOC group includes benzene, toluene, ethylbenzene, and xylenes (BTEX), which are the most common in urban air, and their health effects depend on the level and duration of exposure (David & Niculescu, 2021; Khoshakhlagh *et al.*, 2024).

In Mexico, as BTEX are not considered criteria pollutants, there are no regulations governing their maximum concentrations in ambient air. Therefore, their study and monitoring is important in order to establish regulatory frameworks in the future. In this regard, several studies on BTEX have been conducted in Mexico.

In León, Guanajuato, Mexico, BTEX concentrations in ambient air were evaluated in an urban and industrial area during two climatic seasons. The average BTEX concentrations in the rainy and cold dry seasons were $3.52 \pm 0.36 \mu\text{g}/\text{m}^3$ and $4.11 \pm 0.38 \mu\text{g}/\text{m}^3$, respectively. The authors suggest that the main sources of emissions were motor vehicles and the combustion of fuels with a high sulphur content (Cerón-Bretón *et al.*, 2021a).

On the other hand, (Esteves *et al.* 2015) measured BTEX concentrations in the city of Orizaba, Veracruz, and the carcinogenic risk levels of benzene, analysed by FID gas chromatography. The results suggested that the main contribution of BTEX was from vehicular sources. The cancer risk was 68×10^{-5} , exceeding the acceptable LTCR value of 1×10^{-6} for adults according to the US EPA.

Passive sampling of BTEX allows concentrations to be measured at several sites at once. Its main advantages are its low cost, light weight (weighing 9 g), ease of use, no need for electricity or pumps, and its applicability both indoors and outdoors, even in remote or hard-to-reach areas.

Methodology

Study área

The state of Tabasco is located in the southeast of the Mexican Republic, between the geographical coordinates $18^\circ 39'$ and $17^\circ 15'$ north latitude and $91^\circ 00'$ and $94^\circ 07'$ west longitude. It borders the Gulf of Mexico and Campeche to the north. (INEGI, 2023). The Villahermosa Metropolitan Area, comprising Centro and Nacajuca, covers 2,100 km² and has 833,907 inhabitants. Its main activities are oil mining, trade, construction and services, which account for 73.0% of the state's GDP (Ministry of Economy, 2016).

The study area comprises five urban sites in the city of Villahermosa. These sites were selected based on certain criteria such as population density and their main socio-economic activities. Figure 1 shows a map of the location of the sampling sites and their coordinates.

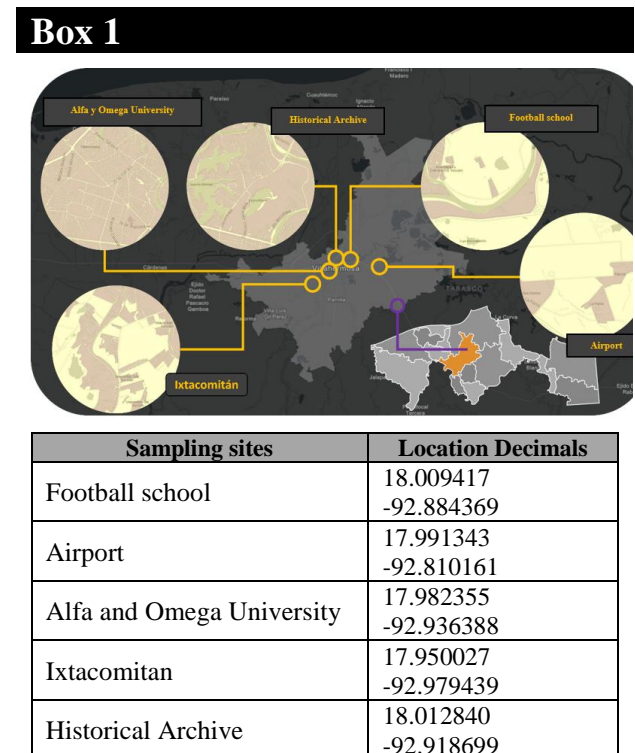

Figure 1

Location and coordinates of sampling sites

Source: Own Elaboration

Passive sampling of BTEX

Sampling was carried out using Sigma Aldrich® Radiello® passive samplers (Figure 2) developed by the Salvatore Maugeri Foundation (FSM) in Padua, Italy, in the mid-1990s (sigma-aldrich.com/supelco) in accordance with European Standard EN 13528-2 (UNE, 2003). This type of passive sampler consists of a stainless steel adsorbent cartridge inserted into a microporous polyethylene membrane.

The stainless steel cartridge (adsorption surface) contains 300 mg of activated carbon and measures 60 mm in length and 5.8 mm in diameter (30–50 mesh). The microporous polyethylene membrane (pore size 5 µm), also called the diffuser body, has a diffusion surface 60 mm long by 16 mm in outer diameter, with a diffusion rate of 80 mL min⁻¹.

The diffusion of contaminants is parallel to the radius of the cartridge, which is why it has been called a radial diffusion sampler. These passive samplers have greater capacity and higher sampling rates compared to traditional passive samplers. (Cerón-Bretón *et al.*, 2025; Pennequin-Cardinal *et al.*, 2005).

Box 2

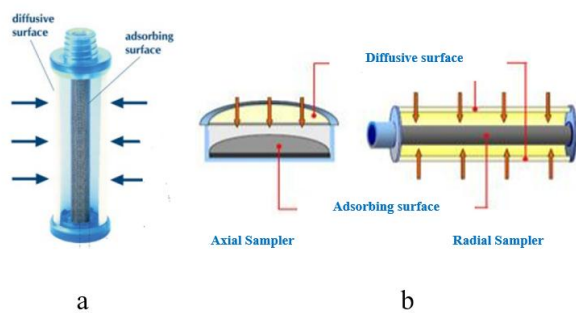

Figure 2

a) Radiello model. b) Axial and radial design of passive samplers

Source: (Sigma-Aldrich, 2025)

A total of 80 samples were collected during the dry (T1) and rainy (T2) seasons of 2024. Each of the Radiello devices was left exposed for two weeks and then analysed using gas chromatography with flame ionisation detection.

Chromatographic análisis

The analytes were recovered from the Radiello® cartridges by chemical desorption, adding two millilitres of carbon disulphide (CS₂), and were subjected to an ultrasonic bath for 10 minutes at a temperature of 10°C (Cerón-Bretón *et al.*, 2021b). The MTA/MA-030/A92 method of the Spanish National Institute for Safety and Hygiene was used for the chemical analysis. The chromatographic analysis of the collected samples was carried out at the Gas Chromatography Research Laboratory of the Faculty of Chemistry of the Autonomous University of Carmen. The gas chromatograph used was a Thermoscientific TRACE GC Ultra Gas Chromatograph with a flame ionisation detector (FID) that uses extra-dry air and ultra-high purity hydrogen and ultra-pure nitrogen as carrier gas and a 30 m x 0.25 mm ID TR-5 capillary column, Methyl type fused silica with a film thickness of 0.25 µm.

Analysis of meteorological parameters: Wind roses and trajectory models

Wind roses were constructed using NOAA's Windrose software (NOAA ARL website) to determine the influence of prevailing winds at the study site for the selected seasons, as well as to establish whether there is a correlation between meteorological parameters and the concentrations obtained for BTEX compounds. Based on data from the National Oceanic and Atmospheric Administration (NOAA), the regressive trajectories of air masses will be analysed using the HYSPLIT trajectory model. These trajectories show the transport and dispersion of pollutants originating from various sources.

Statistical análisis

This was performed using the Excel XLSTAT statistical package, version 2019. The non-parametric Friedman test ($\alpha = 0.05$) statistical tools were used to evaluate the existence of significant differences between sampling seasons and the concentrations obtained from BTEX, as well as to determine whether these values come from the same population or not, and thus be able to infer whether there is seasonal or spatial variation. Principal Component Analysis (PCA) was also performed to explain the variance and determine the structure of the data set.

The information obtained from the PCA is used to identify whether a contaminant is secondary or primary, or to identify the specific source of the contaminants. For descriptive statistics, box plots were created to visualise the concentrations, means, maximums and averages of the measured contaminants; in this way, it is easy to identify which contaminant has the highest average concentrations and even if any patterns occurred during sampling.

Health risk assessment

The carcinogenic potential of benzene is widely known (Vega-Campa *et al.*, 2023). The European Union recommends an annual limit of $5 \mu\text{g m}^{-3}$ for benzene in ambient air and a minimal risk level for cancer by inhalation (MRL of 1 in 10,000), while the US EPA sets a value of 4.0 ppbv for this pollutant (US EPA, 2012). In this study, the methodology proposed by (Zhang *et al.* 2015) was used to determine daily exposure (E), lifetime cancer risk (LTCR) and cancer non-risk potential (HQ).

Assessment of the carcinogenic risk of benzene

An individual's daily exposure by inhalation can be calculated as:

$$E = \frac{C \times IRa \times Da}{BW} \quad [1]$$

Where:

E = is the daily exposure by inhalation in mg/kg per day.

C = is the average concentration of benzene in mg/m^3 .

IRa = is the inhalation rate for an adult ($0.83 \text{ m}^3 \text{ h}^{-1}$) (US EPA, 1998).

Da = is the duration of exposure for an adult (24 hr/day).

BW = is the average adult body weight (65 kg).

The lifetime cancer risk (LTCR) is calculated as:

$$LTCR = E \times SF \quad [2]$$

Where:

$LTCR$ = is the lifetime cancer risk.

SF = is the slope factor ($2.98 \text{ E}^{-02} \text{ kg day/mg}$).

The slope factor for inhalation of toxic substances (SF) is when the carcinogenic effect of exposure is considered linear.

An SF value of $2.98 \text{ E}^{-02} \text{ kg day/mg}^{-1}$ was considered for benzene in accordance with (US EPA, 2014). The values determined will be compared with the permissible limit values established by the US EPA and the WHO. The non-carcinogenic risk of benzene will be measured as a hazard quotient (HQ), calculated as:

$$HQ = \frac{C}{RfC} \quad [3]$$

Where:

C = is the daily intake (μm^{-3})

RfC = This is the inhalation reference concentration proposed by the US EPA for benzene ($0.03 \mu\text{g m}^{-3}$), toluene ($5 \mu\text{m}^{-3}$), ethylbenzene ($1 \mu\text{m}^{-3}$) and xylene ($0.1 \mu\text{m}^{-3}$) (US EPA, 2002).

Results

Descriptive statistics for BTEX

During seasons T1 and T2, benzene showed the highest average concentrations at the Historical Archive Site with $0.5188 \mu\text{g m}^{-3}$, a maximum of $0.7658 \mu\text{g m}^{-3}$ and a minimum of $0.2703 \mu\text{g m}^{-3}$. The Football School site had the lowest concentrations of this toxic contaminant, with an average of $0.1292 \mu\text{g m}^{-3}$, a maximum of $0.2864 \mu\text{g m}^{-3}$, and a minimum of $0.0510 \mu\text{g m}^{-3}$ (Figure 3).

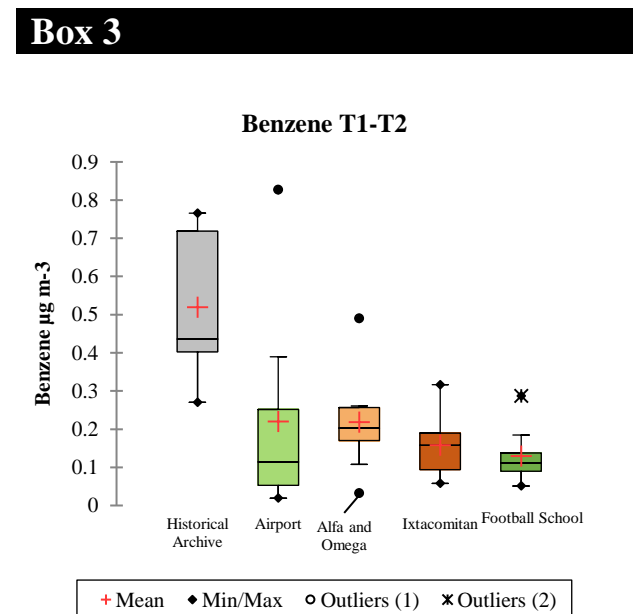

Figure 3

Descriptive statistics for benzene seasons T1-T2

Source: Own Elaboration

In the case of toluene, the descriptive statistics are shown in Figure 4. The site with the highest concentrations in both seasons was Alfa y Omega, with an average of $0.8307 \mu\text{g m}^{-3}$ and maximum and minimum values of 3.6581 and $0.2978 \mu\text{g m}^{-3}$, respectively. The site Escuela de futbol had the lowest concentrations, with an average of $0.2562 \mu\text{g m}^{-3}$, very similar to the site Ixtacomitán, with an average of $0.2651 \mu\text{g m}^{-3}$.

Box 4

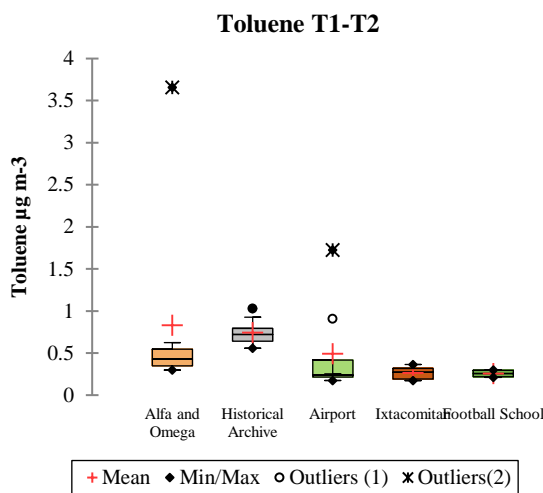

Figure 4
Descriptive statistics for toluene seasons T1-T2.
Source: Own Elaboration

Figure 5 shows the descriptive statistics for ethylbenzene for both seasons T1 and T2. It can be seen that the airport had the highest concentrations, with an average of $0.6411 \mu\text{g m}^{-3}$, a minimum value of $0.2551 \mu\text{g m}^{-3}$, and a maximum value of $2.0606 \mu\text{g m}^{-3}$.

Box 5

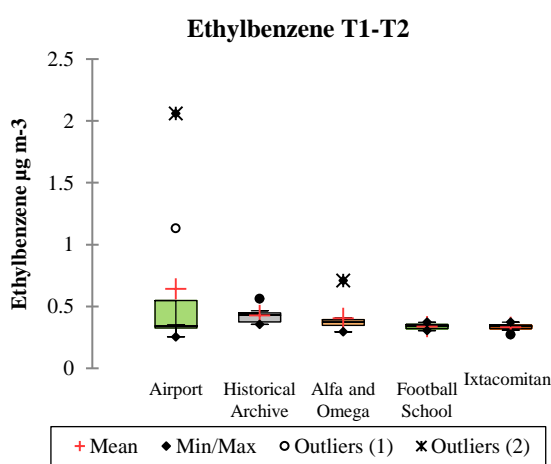

Figure 5
Descriptive statistics for ethylbenzene seasons T1-T2.
Source: Own Elaboration

Xylene also had its highest concentrations at the Airport site, with an average of $0.6254 \mu\text{g m}^{-3}$ and a minimum and maximum of 0.2298 and $2.1153 \mu\text{g m}^{-3}$, respectively, as shown in Figure 6.

Box 6

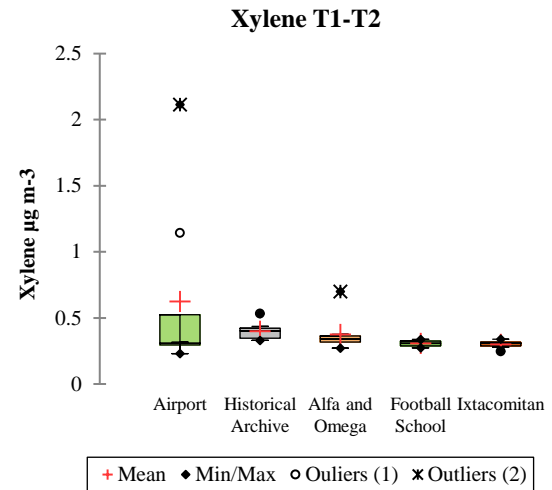

Figure 6
Descriptive statistics for Xylene seasons T1-T2.
Source: Own Elaboration

Bivariate Analysis and Principal Component Analysis

Spearman's correlation matrices were constructed as a bivariate analysis technique to identify relationships between the different BTEX measured, as well as principal component analysis (PCA) to identify groups of variables. Table 1 shows Spearman's correlation matrix and PCA for BTEX concentrations at all sites measured.

Box 7

Table 1
Spearman correlation matrix and PCA for BTEX concentrations for all sites measured during the dry and rainy seasons

Variables	Benzene	Toluene	Ethylbenzene	Xylene
Football School				
Benzene	1	0.786	0.262	0.238
Toluene	0.786	1	0.238	0.286
Ethylbenzene	0.262	0.238	1	0.976
Xylene	0.238	0.286	0.976	1

Values in bold are different from 0 with a significance level of $\alpha=0.05$.

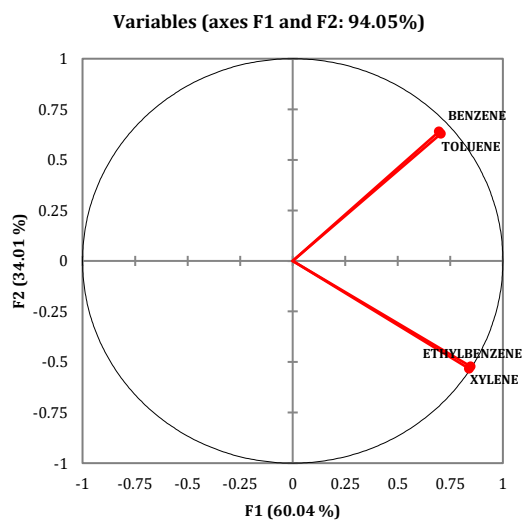

Variables Football School	Benzene	Toluene	Ethylbenzene	Xylene
Benzene	1	0.881	0.643	0.452
Toluene	0.881	1	0.690	0.714
Ethylbenzene	0.643	0.690	1	0.643
Xylene	0.452	0.714	0.643	1

Values in bold are different from 0 with a significance level of alpha=0.05.

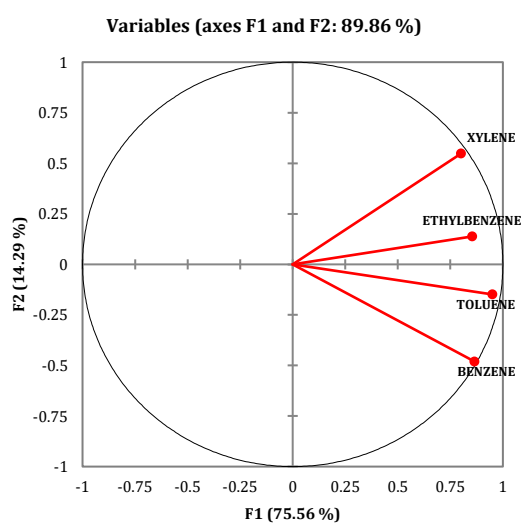

Variables Football School	Benzene	Toluene	Ethylbenzene	Xylene
Benzene	1	0.833	0.833	0.833
Toluene	0.833	1	0.857	0.857
Ethylbenzene	0.833	0.857	1	1.000
Xylene	0.452	0.714	0.643	1

Values in bold are different from 0 with a significance level of alpha=0.05.

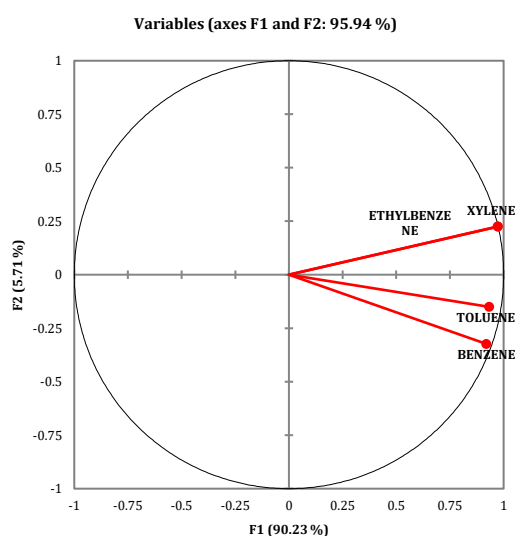

Variables Football School	Benzene	Toluene	Ethylbenzene	Xylene
Benzene	1	0.643	-0.238	-0.190
Toluene	0.643	1	0.310	0.333
Ethylbenzene	-0.238	0.310	1	0.976
Xylene	-0.190	0.333	0.976	1

Values in bold are different from 0 with a significance level of alpha=0.05.

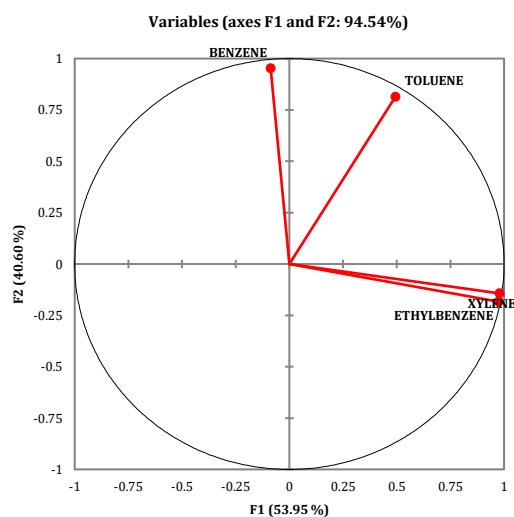

Variables Football School	Benzene	Toluene	Ethylbenzene	Xylene
Benzene	1	0.762	0.714	0.714
Toluene	0.762	1	0.833	0.833
Ethylbenzene	0.714	0.833	1	1.000
Xylene	0.714	0.833	1.000	1

Values in bold are different from 0 with a significance level of alpha=0.05.

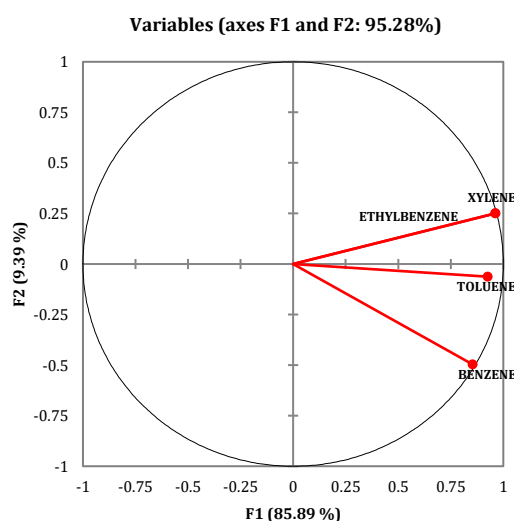

Source: Own Elaboration

Spearman's correlation analysis revealed positive and significant relationships between BTEX compounds at most sites, indicating common emission sources associated with fossil fuel combustion and vehicular traffic. At the Football School and the Airport, the strongest correlations were between pairs such as benzene-toluene ($r = 0.786$) and ethylbenzene-xylene ($r = 0.976$), linked to mobile sources (vehicles and aircraft) (Mugica-Álvarez *et al.*, 2020). At Alfa y Omega and the Historical Archive, high and uniform correlations reflected a single dominant source: heavy urban traffic.

In contrast, Ixtacomitán showed a differentiation of benzene from other compounds, suggesting additional sources such as domestic combustion or waste burning. This differential pattern of benzene is consistent with its greater chemical stability and ability to remain in the atmosphere longer (ATSDR, 2019). Principal component analysis (PCA) identified patterns of variation and dominant sources of BTEX compounds at the five sites. In general, two main groups were distinguished: one associated with vehicular traffic and the other with diffuse or industrial emissions. At the Football School and Ixtacomitán, mixtures of mobile and industrial sources were observed, while at the Airport, Alfa y Omega and Archivo Histórico, a single vehicular source, linked to urban or air traffic, predominated. The high explained variances (60–90%) in the first components confirm that fossil fuel combustion is the main cause of BTEX presence in the areas studied.

Urban Containment Perimeters

To determine the portion of the population exposed to these toxic contaminants at each site, a general classification of Urban Containment Perimeters (PCU) was made as follows U1: Areas with the highest concentration of jobs and economic activities, representing the consolidated core of the city. U2: Areas with basic services such as water and drainage, where housing development is promoted near the U1 perimeter; and finally U3: Areas of urban expansion adjacent to the consolidated areas (U1 and U2), delimited according to the population size of the city (SEDATU, 2018).

The points to highlight are that the Football School Site was classified as (U3) as it is located in a conurbation with a high influx of people and the presence of agricultural and livestock activities. The main access is by motorised transport, which increases the potential for vehicle emissions. The Airport site, classified as (U2), is located outside the urban area but has a significant urban impact due to the high number of daily users and its proximity to residential neighbourhoods and the Yumka tourist park. It is an area with high mobility and constant traffic flow. The Alfa y Omega site (U1) is a fully urbanised and consolidated area with a high concentration of services and businesses: shopping centres, petrol stations and parks.

It is an area of intense economic and social activity, with heavy vehicle and pedestrian traffic. The Ixtacomitán site (U3) is located on the southwestern outskirts of the city and is predominantly residential with little commercial activity but close to a busy transport route, making it a potential point for capturing emissions. Finally, the Archivo Histórico (U2) site is located very close to the city centre, with a wide range of services and urban activities and facing one of the busiest roads, which contributes to exposure to pollutants.

Taken together, the five sites show an urban gradient ranging from consolidated areas (U1) to peripheral areas (U3), allowing for a comparison of BTEX concentrations according to the degree of urbanisation and human activity (Figure 7).

Box 8

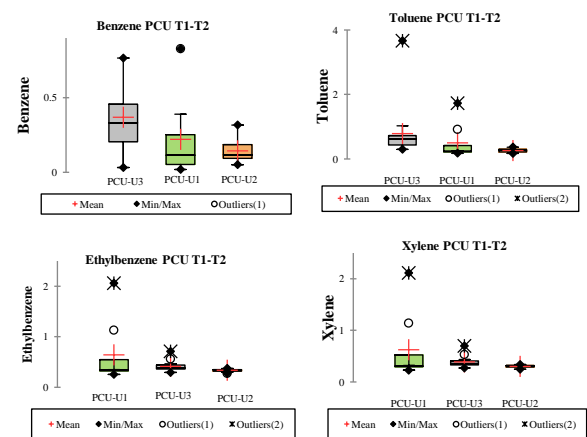

Figure 7

BTEX Urban Containment Perimeters (PCU) for seasons T1 and T2

Source: Own Elaboration

The results obtained show clear spatial and temporal variability in BTEX concentrations within the Urban Containment Perimeters (PCU-U1, U2 and U3). During the dry season (T1), higher BTEX concentrations were observed, especially in PCU-U3, which corresponds to areas with higher vehicle density and intensive commercial activity. This is consistent with previous studies conducted in tropical urban environments, where lower relative humidity and greater atmospheric stability during the dry season favour the accumulation of volatile organic compounds (VOCs) due to lower vertical dispersion (Bretón *et al.*, 2018).

During the rainy season (T2), the average concentrations of all compounds decrease, especially in PCU-U2, which can be attributed to increased precipitation and greater atmospheric turbulence, which promote the removal and dilution of pollutants.

However, specific peaks were recorded at specific sites (such as PCU-U1) that could be associated with local mobile sources or fugitive hydrocarbon emissions related to service stations and automotive workshops.

Statistical analysis of normality applied to BTEX (benzene, toluene, ethylbenzene and xylenes) concentrations in the PCU-U1, PCU-U2 and PCU-U3 areas during seasons T1 and T2 revealed that the data do not follow a normal distribution, as indicated by the p-values obtained in the Shapiro-Wilk, Anderson-Darling, Lilliefors and Jarque-Bera tests. From an environmental perspective, this variability suggests the existence of intermittent emission sources or external influences such as weather conditions and urban and industrial activity patterns that significantly alter the levels of these pollutants in the air. The non-normal behaviour of the data also shows that the dispersion and accumulation processes of these compounds are neither constant nor uniform.

In terms of meteorology, wind roses were created and a higher average wind speed was identified in the dry season (2.83 m/s) compared to the rainy season (2.32 m/s). This analysis allows us to infer the predominant direction of air mass transport and, therefore, to estimate the possible origin of the BTEX compounds detected. At most sites (Airport, Alfa y Omega, Ixtacomitán, and Escuela de Fútbol), winds come from the east-northeast (56° – 64°) during the dry season, with high resulting vectors (35–38%), indicating a defined and stable prevailing direction. Under these conditions, it is likely that the compounds detected originate from sources located to the east and northeast of the city, where there are high-traffic roads and light industrial areas.

BTEX ratios

The toluene/benzene (B/T) and xylene/ethylbenzene (X/E) ratios are calculated to determine the probable origin of BTEX at a specific site. Ratios (B/T) with values lower than 2-3 are specific to sites with a high influence of motor vehicle traffic (Elbir *et al.*, 2006).

The (X/E) ratio is used to deduce the photochemical age of air masses, and thus to determine whether they are local and from fresh emissions (values <4.4), or from regional aged air masses (Keymeulen *et al.*, 2001). For the dry season at all sampling sites, the average B/T ratio was 2.529, and for the rainy season, it was 2.946, indicating that the recorded BTEX emissions probably originated from vehicular sources. On the other hand, for the X/E ratio, the averages for all sites in the dry season were 0.920 and 0.922 for the rainy season, indicating that the measured BTEX concentrations were from fresh, local emissions.

Health risk assessment análisis

The cancer risk index was calculated as a result of benzene exposure for the adult and child population living in the study area. The lifetime cancer risk (LTCR) values at the five study sites for seasons T1 and T2 are shown in Figure 8.

Box 9

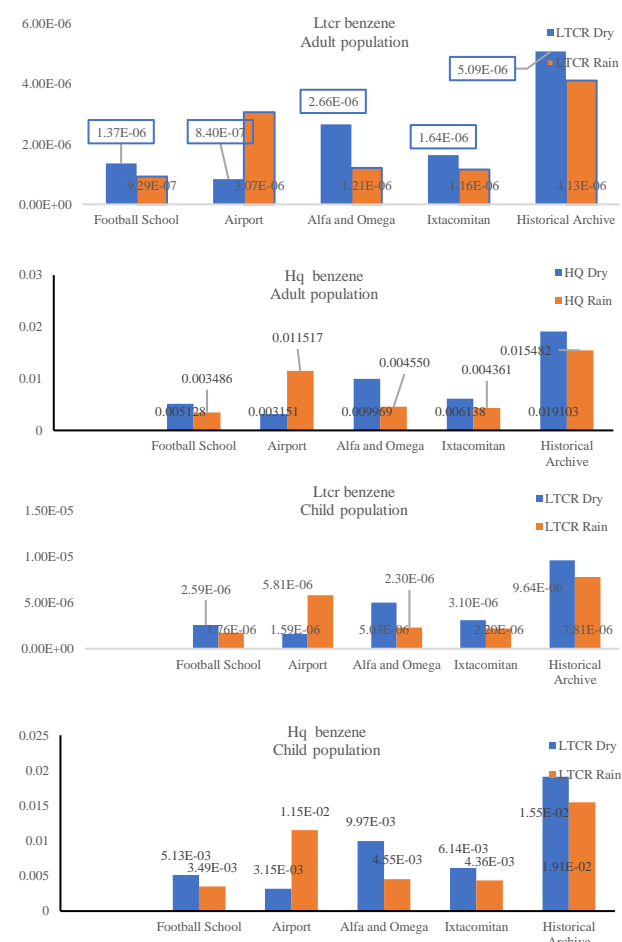

Figure 8

LTCR and HQ values for the five study sites for benzene inhalation for adults and children during both study seasons

Source: Own Elaboration

The lifetime cancer risk (LTCR) values obtained for the five study sites, both in the adult and child populations, show significant variations between the dry and rainy seasons, being higher in the dry season for all sites, except for the airport site, which had higher values in the rainy season. According to international guidelines, the reference value established for LTCR is 1×10^{-6} , while the WHO reference value is 1×10^{-5} . The average LTCR for benzene in the adult population in both seasons was 3.20459×10^{-5} and for children 8.2885×10^{-03} , showing that there is a risk for both populations as they exceed the established limits.

The HQ values for the different compounds are below the threshold of 1.0 at all sites and for both seasons, indicating a non-carcinogenic risk. However, slight increases in HQ are observed at the study sites during the dry season and at sites with higher vehicular or industrial activity.

Conclusions

The study on BTEX in Villahermosa, Tabasco showed notable spatial and temporal differences. It was observed that the highest concentrations were recorded at the airport and the historical archive, mainly associated with heavy traffic and urban activities, while the football school and Ixtacomitán presented low levels and greater dispersion of pollutants. Weather conditions had a direct influence, as higher concentrations were detected during the dry season due to lower atmospheric dispersion, and during rainfall, precipitation and humidity reduced average concentration levels.

Statistical analysis (Spearman and PCA) confirmed that toluene, ethylbenzene and xylenes share a common vehicular source, while benzene also comes from stationary or industrial sources. In terms of health risk, the carcinogenic risk from benzene exceeded the EPA and WHO reference values, representing a potential danger to the population, especially during the dry season; the other compounds did not show an immediate risk, but they did show a cumulative risk.

The results obtained highlight the urgent need to incorporate BTEX compounds into national air quality monitoring systems, given their potential adverse effect on human health.

It is also recommended to strengthen vehicle emission management and area source control strategies, promote the use of clean fuels, and conduct continuous environmental monitoring campaigns in medium-sized cities such as Villahermosa, where urbanisation and vehicular traffic are critical factors in pollution.

Declarations

Conflict of interest

The authors declare that they have no conflict of interest. They have no known financial interests in Competencia or personal relationships that could have influenced the information reported in this chapter.

Contribution of the authors

Uc-Chi, Martha Patricia: was responsible for writing the introduction and graphic summaries. She carried out the analysis of the data obtained.

Cerón-Bretón, Julia Griselda: was responsible for writing the discussion of the results.

Cerón-Bretón, Rosa María: was responsible for writing the conclusions and references. She also participated in the final revisions of the book chapter.

Silis-Esquivel, Jhoanna: was responsible for writing the results and preparing the tables and figures.

Availability of data and materials

The data are available upon request at: muc@pampano.unacar.mx

Funding

This work had no sources of funding.

Abbreviations

ACP	Principal Component Analysis
ATSDR	Agency for Toxic Substances and Disease Registry
BTEX	Benzene, toluene, ethylbenzene, and xylenes
CONAPO	National Population Council Government

Article

COVs	Volatile organic compounds	
FSM	Salvatore Maugeri Foundation	
GC-FID	Gas chromatography with flame ionisation detector	
HQ	Hazard Quotient	
HYSPLIT	Hybrid Lagrangian Trajectories	Single-Particle Integrates
INEGI	National Institute of Statistics and Geography	
LTCR	Lifetime cancer risk	
MRL	Minimal Risk Level	
NOAA	National Oceanic and Atmospheric Administration	
OMS	World Health Organisation	
PCU	Urban Containment Perimeters	
US EPA	United States Environmental Protection Agency	
XLSTAT	Statistical Software for Excel	

References

Background

Briz-Redón, Á., Belenguer-Sapiña, C., & Serrano-Aroca, Á. (2021). [Changes in air pollution during COVID-19 lockdown in Spain: a multi-city study.](#) *Journal of environmental sciences*, *101*, 16-26.

Ceron-Breton, J.G., Cerón Bretón, R.M., Kahl, J.D.W. *et al.* (2021a) Concentrations, sources, and health risk associated with exposure to BTEX at ten sites located in an urban-industrial area in the Bajío Region, Mexico. *Air Qual Atmos Health* **14**, 741–761. <https://doi.org/10.1007/s11869-021-00976-1>

David, E., & Niculescu, V. C. (2021). [Volatile organic compounds \(VOCs\) as environmental pollutants: occurrence and mitigation using nanomaterials.](#) *International journal of environmental research and public health*, *18*(24), 13147.

ISSN 2531-2960
RENIECYT: 1702902
ECORFAN® All rights reserved.

Esteves, D., Dimas, N. E., Casanova, G. M.T; Cerón, B. J.G; Cerón, B. R. M., Rustríán, P. E., Houbron, E. y Cima, C. (2015). [Niveles de BTEX en aire ambiente y niveles de riesgo carcinogénico de benceno en un sitio urbano del centro de Veracruz.](#) 2º congreso Nacional AMICA 2015. Congreso llevado a cabo en Puebla, Puebla.

Instituto Nacional de Estadística y Geografía. (2023). [Tabasco. Información geográfica.](#) INEGI.

Khoshakhlagh, A. H., Mohammadzadeh, M., Gruszecka-Kosowska, A., & Oikonomou, E. (2024). [Burden of cardiovascular disease attributed to air pollution: a systematic review.](#) *Globalization and Health*, *20*(1), 37.

Organización Panamericana de la Salud. OPS (2014, 7 de mayo). [La calidad del aire se está deteriorando en muchas de las ciudades del mundo.](#)

Essentials

Asociación Española de Normalización. (2003). [UNE-EN 13528-2:2003. Calidad del aire ambiente. Captadores difusivos para la determinación de las concentraciones de gases y vapores. Parte 2: Requisitos específicos y métodos de ensayo.](#) UNE.

Cerón Bretón, J. G., Cerón Bretón, R. M., Aguilar Uacán, C. A., Montalvo Romero, C., Espinosa Guzmán, A. A., Carranco Lozada, S. E., Ramírez Lara, E., Espinosa Fuentes, M. d. l. L., & Uc Chi, M. P. (2025). [Assessment of Aromatic Hydrocarbons in Urban Air: A Study from a Northern Mexican Megacity.](#) *Atmosphere*, *16*(6), 649. <https://doi.org/10.3390/atmos16060649>

Ceron-Breton, J.G., Cerón Bretón, R.M., Kahl, J.D.W. *et al.* (2021b) Concentrations, sources, and health risk associated with exposure to BTEX at ten sites located in an urban-industrial area in the Bajío Region, Mexico. *Air Qual Atmos Health* **14**, 741–761. <https://doi.org/10.1007/s11869-021-00976-1>

Instituto Nacional de Estadística y Geografía. (2024, 2 de diciembre). [Cuentas económicas y ecológicas de México \(CEEM\), 2023](#) [Comunicado de prensa n.º 690/24]. INEGI.

Uc-Chi, Martha Patricia, Cerón-Bretón, Julia Griselda, Cerón-Bretón, Rosa María and Silis-Esquivel, Jhoanna. [2025]. [Spatial and temporal variation of BTEX in Villahermosa, Tabasco, during the dry and rainy seasons of 2024.](#) *Journal of Technological Development*. 9[22] 1-12: e10922112 <https://doi.org/10.35429/JTD.2025.9.22.1.1.12>

Pennequin-Cardinal, A., Plaisance, H., Locoge, N., Ramalho, O., Kirchner, S., & Galloo, J. C. (2005). Performances of the Radiello® diffusive sampler for BTEX measurements: Influence of environmental conditions and determination of modelled sampling rates. *Atmospheric Environment*, 39(14), 2535-2544.

Secretaría de Economía. (2016). Información económica y estatal. https://www.gob.mx/cms/uploads/attachment/file/157945/tabasco_2016_1024.pdf

sigma-aldrich.com. (n.d.). sigma-aldrich.com. Retrieved November 30, 2024, from https://www.sigmaaldrich.com/deepweb/assets/sigmaaldrich/marketing/global/documents/327/088/radiello_a1_a8.pdf

Sigma-Aldrich. (2025). *What is radiello® diffusive sampling?* Sigmaaldrich.com. <https://www.sigmaaldrich.com/MX/es/technical-documents/technical-article/environmental-testing-and-industrial-hygiene/air-testing/diffusive-sampling-system>

Supports

United States Environmental Protection Agency (US EPA), 2012. Benzene. Retrieved from <https://www.epa.gov/sites/default/files/2016-09/documents/benzene.pdf>

United States Environmental Protection Agency. (US EPA), 1998. *Methodology for assessing health risks associated with multiple pathways of exposure to combustor emissions.*

United States Environmental Protection Agency (US EPA), 2014. Risk assessment guidance for superfund volume I: human health evaluation manual (part F, supplemental guidance for inhalation risk assessment): final [EPA Report] (EPA/540/-R-070/002). https://www.epa.gov/sites/default/files/2015-09/documents/rags_a.pdf

United States Environmental Protection Agency (USEPA), 2002. Integrated Risk Information System (IRIS). Toxicological review benzene (non-cancer effects) (EPA/635/R-02/001F). <https://assessments.epa.gov/risk/document/&deid=12160>

Vega-Campa, M., André, F. J., & Soliño, M. (2023). Socioeconomic driving forces behind air polluting emissions in Mexico. *PLoS ONE*, 18(10).

Zhang, Z., Wang, X., Zhang, Y., Lü, S., Huang, Z., Huang, X., & Wang, Y. (2015). *Ambient air benzene at background sites in China's most developed coastal regions: Exposure levels, source implications and health risks.* *Science of the Total Environment*, 511, 792–800.

Differences

Agencia para Sustancias Tóxicas y Registro de Enfermedades ATSDR (2019). Resumen de Salud Pública Benceno. Recuperado de https://www.atsdr.cdc.gov/es/toxfaqs/es_tfacts3.html

Bretón, J. G. C., Bretón, R. M. C., Guarnaccia, C., Severino, R. del C. L., Marrón, M. R., Guzmán, A. R., Chi, M. P. U., Angel, G. H., & Rejon, Y. A. S. (2018). Characterization and sources of aromatic hydrocarbons (BTEX) in an urban site of Tijuana, Baja California, Mexico. AIP Conference Proceedings. <https://doi.org/10.1063/1.5045426>

Mugica-Álvarez, V., Magaña-Reyes, M., Martínez-Reyes, A., Figueroa-Lara, J., Blanco-Jiménez, S., Goytia-Leal, V., Páramo-Figueroa, V. H., & García-Martínez, R. (2020). Updating real-world profiles of volatile organic compounds and their reactivity estimation in tunnels of Mexico City. *Atmosphere*, 11(12), 1339. <https://doi.org/10.3390/atmos11121339>

Secretaría de Desarrollo Agrario, Territorial y Urbano. SEDATU (2018). Modelo Geoestadístico de los Perímetros de Contención Urbana (PCU). Gobierno de México. https://www.gob.mx/cms/uploads/attachment/file/333659/Modelo_Geoestadistico_Per_metros_de_Contencion_Urbana_2018.pdf

Discussions





Elbir, T., Mangır, N., Kara, M., Simsir, S., Eren, T., & Ozdemir, S. (2006). Development of a GIS-based decision support system for urban air quality management in the city of Istanbul. *Atmospheric Environment*, 40(23), 4230–4242.

Keymeulen, R., Görgényi, M., Héberger, K., Priksane, A., & Van Langenhove, H. (2001). Benzene, toluene, ethyl benzene and xylenes in ambient air and *Pinus sylvestris* L. needles: a comparative study between Belgium, Hungary and Latvia. *Atmospheric Environment*, 35(36), 6327-6335.

Metallic particulates in pulmonary tissue

Partículas metálicas en tejido pulmonar

Peña-García, Laura Elizabeth ^{a*}

^a  Universidad de Guadalajara •  U-4752-2018 •  0000-0002-9008-1339 •  311129

Classification:

Area: Physics, Mathematics and Earth Sciences
Field: Earth and Space Sciences
Discipline: Geology
Subdiscipline: Environmental Geology

 <https://doi.org/10.35429/JTD.2025.9.22.2.1.9>

History of the article:

Received: January 13, 2025
Accepted: November 10, 2025

*  [\[laura.pgarcia@academicos.udg.mx\]](mailto:laura.pgarcia@academicos.udg.mx)



Abstract

This paper examines the toxicological consequences of metal particles (PM 2.5) deposition in lung tissue. Originating from sources such as vehicular traffic (brake/tire abrasion and emissions), these nanoparticles pose a significant health risk, particularly in high-traffic areas. Chronic exposure increases the likelihood of developing lung cancer and other respiratory and inflammatory diseases. The central mechanism of toxicity involves the induction of oxidative stress and the generation of cellular inflammation, leading to DNA damage and the activation of pro-cancer pathways, even in non-smokers. Epidemiological studies confirm an elevated risk for residents living within 500 meters of high-volume roadways.

Resumen

Este documento examina las consecuencias toxicológicas de la deposición de partículas metálicas (PM_{2.5}) en tejido pulmonar. Provenientes de fuentes como el tráfico vehicular (abrasión de frenos, neumáticos y emisiones), estas nanopartículas representan un riesgo significativo para la salud, especialmente en zonas de alto flujo. La exposición crónica aumenta la probabilidad de desarrollar cáncer de pulmón y otras enfermedades respiratorias e inflamatorias. El mecanismo central de toxicidad es la inducción de estrés oxidativo y la generación de inflamación celular, lo que conduce al daño del ADN y a la activación de vías pro-cancerígenas, incluso en personas no fumadoras. Estudios epidemiológicos confirman un riesgo elevado para residentes a menos de 500 metros de carreteras con alto volumen de tráfico.

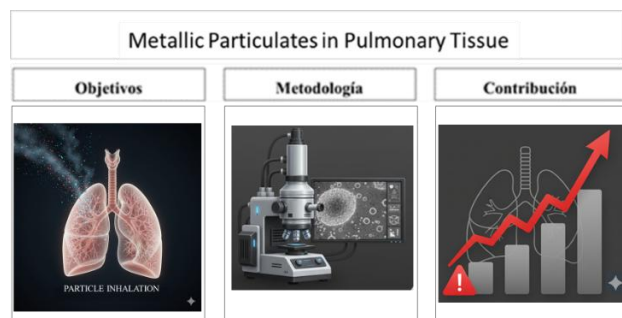

Metallic Particulates, pulmonary tissue, PM_{2.5}



Partículas metálicas, tejido pulmonar, PM_{2.5}

Area: Promotion of frontier research and basic science in all fields of knowledge

Citation: Peña-García, Laura Elizabeth. [2025]. Metallic particulates in pulmonary tissue. Journal of Technological Development. 9 [22] 1-9: e20922109



ISSN 2531-2960/© 2009 The Authors. Published by ECORFAN-México, S.C. for its Holding Spain on behalf of Journal of Technological Development. This is an open-access article under the license CC BY-NC-ND license [<http://creativecommons.org/licenses/by-nc-nd/4.0/>]

Peer review under the responsibility of the Scientific Committee MARVID® in the contribution to the scientific, technological and innovation Peer Review Process through the training of Human Resources for the continuity in the Critical Analysis of International Research.



Introduction

Measuring exposure to numerous pollutants is complex because adequate health information and surveillance systems are not always available to assess the magnitude and severity of the risks. Some substances below certain levels are not dangerous, but other agents such as allergens, ionising radiation, air pollutants and carcinogenic chemicals can pose a risk at levels higher than those observed (Vargas, 2005).

According to the World Health Organisation (WHO), exposure to air pollution is responsible for millions of premature deaths each year. The most recent figures, from associated reports by the WHO and the Health Effects Institute (HEI), estimate 8.1 million deaths annually in 2021, making air pollution the second leading risk factor for death worldwide (WHO, 2021; UN News, 2024). The main causes of death are non-communicable diseases (NCDs), such as ischaemic heart disease, stroke, chronic obstructive pulmonary disease (COPD) and lung cancer. The WHO also estimates that air pollution should be considered an ‘invisible pandemic’ due to its widespread impact on public health.

The rapid development of nanotechnology has driven the growing use of metallic nanoparticles (MNPs) in a wide range of industrial sectors and consumer products. This advance has led to a significant increase in human and environmental exposure, which is a public health priority.

Metallic particles in lung tissue are a clear example of how environmental pollution directly affects human health.

There are different routes of entry into the human body, one of which is through the inhalation of PM. Due to their small diameters, this type of material can include metal nanoparticles, which are able to evade the upper filtration mechanisms and penetrate deep into the pulmonary alveoli.

The respiratory system is the main route of entry for MP due to inhalation. Coarse particles that are transported by air (size $\leq 10 \mu\text{m}$; PM 10) are deposited in the upper respiratory system. The material can be as fine as aerosols and can be transported by the bloodstream.

The presence of metal particles in human lung tissue is intrinsically linked to exposure to PM, especially fine (PM_{2.5}) and ultrafine (PM_{0.1}) particles present in air pollution (vehicular traffic, industrial emissions, combustion, etc.) or in occupational environments (mining, welding, etc.). Recent research confirms that the most toxic components of PM_{2.5} include metals and metalloids such as arsenic, lead, cadmium, chromium, and mercury. These are deposited in the lung, acting as a reservoir of acute and chronic exposure. People living in large cities also accumulate PM in their lungs throughout their lives due to the high levels of air pollution commonly found in urban environments (Ellwanger *et al.*, 2025). The tiny size of PM (<100 nm) is one of their defining characteristics, as it facilitates their penetration through cell membranes and other biological barriers. Several studies have shown that smaller particle sizes correlate with greater toxicity and increased cellular uptake.

Study area

The area where the ZMG is located has a specific type of rock and age. Regionally, the origin of these rocks is mainly associated with volcanic activity and, tectonically, is considered active. To a lesser extent, there is material that has been degraded in situ or transported to lower areas and agglutinated as alluvial rocks.

There are also rhyolite rocks and rhyolitic tuffs containing predominantly paramagnetic minerals. Rocks with low ferromagnesian mineral (FM) content are found west of the city, in the Sierra de La Primavera. In the central part, rocks with a high ferromagnesian mineral content can be found in at least three small volcanic formations of andesite-basalt origin, as well as in the east and south, where the material is basalt or andesite. The Santiago River with FM rocks is located in the northeast. This explains the natural presence of these minerals in the area (Garnica *et al.*, 2017).

The AMG has been built on volcanic rocks of different chemical compositions. The most recent ones, associated with the emission of acid tuffs from aerial fall and flow, come from the Sierra de La Primavera (SLP), corresponding to the Pleistocene-Holocene Quaternary, whose age varies from 140,000 to 27,000 years.

These rocks cover older, thicker rocks (the areas near the SLP with an approximate thickness of 300 m) (Maciel *et al.*, 2015) and with less depth (until they practically disappear) towards the area of the Río Grande de Santiago ravine. They originate from older volcanic edifices such as the El Cuatro, Gachupín, and El Tesoro volcanoes.

These rocks were emitted approximately one million years ago (Ma), i.e. in the Pliocene Tertiary, around 8.7 to 13 Ma, and correspond mainly to Miocene andesite and basalt that were emitted by fissures or calderas that are not visible today (Maciel *et al.*, 2015).

The different volcanoes and rocks that make them up generate different magnetic responses. To the west, the La Primavera domes (rhyolite and airfall tuffs, a material widely used in construction) respond. These volcanic centres emitted ash that dispersed mainly towards the central part of the ZMG, while in the eastern and southern parts there are volcanic rocks and edifices, such as Cerro del Cuatro (basalt) and its associated volcanoes, Gachupín or Cerro del Tesoro (with a ferromagnetic response, whose material is used for construction), and the very distant Colima volcano (also FM), which is considered active and whose ash has reached the ZMG.

Due to volcanic activity, a thick crust of FM volcanic rocks has formed in the region beneath the most recent layer, which are the products of the SLP. One need only descend to the bed of the Río Grande de Santiago to see that everything that outcrops is volcanic, consisting of older FM rocks, now exposed at the surface, with an approximate age of 5 Ma.

Among the volcanic rocks, we have basalts and andesites, which are lavas that are very fluid at the time of their emission and form cone-shaped volcanic edifices, such as El Cuatro and Gachupín, among others, while other lavas, such as rhyolites, are very acidic and viscous and form domes, such as C. Colli, El Chapulín, and El Tule.

Considering that the last emission of tuffs from the SLP covered the entire area where the urban sprawl has expanded, it is not feasible to superficially appreciate the rocks existing in the subsoil.

This is only possible if the paleotopography is abrupt, as in the case of C. del Cuatro, Gachupín, Cofre de Tesoro, and other small monogenetic volcanic features that were not covered by this ash emission, or if there are faults in this area, such as those observed in Río Santiago or towards the Tesisán area.

The last deposit of FM volcanic rocks in the study area is the ash from the Colima volcano (basic andesites) which historically reached Coahuila and Mexico City in 1913 and 1918, passing through the AMG, and may be present in some of the particles found in this study.

It should be noted that all the rocks mentioned are used in the construction of housing units, factories and land transport routes, so the disintegration and dispersion of the minerals that form the rocks into small particles has probably also been recorded in the study.

Since the end of the 20th century, the Guadalajara metropolitan area (ZMG) has already experienced high levels of pollutants. Toxicity varies considerably depending on the metal that makes up the nanoparticle. For example, it has been determined that copper oxide nanoparticles are significantly more potent in inducing cytotoxicity and DNA damage than titanium dioxide nanoparticles. A key mechanism of toxicity is the dissolution of the nanoparticle, which releases metal ions into the biological medium, which can alter cellular homeostasis and exert direct toxic effects.

In 1996, the ozone (O₃) standard was exceeded on 60% of the days of the year and the fine particulate matter (PM₁₀) standard on more than 30% of the days. The main pollutants that have been monitored include ozone (O₃), carbon monoxide (CO), nitrogen dioxide (NO₂), sulphur dioxide (SO₂) and suspended particulate matter (PM₁₀ and PM_{2.5}). Another factor contributing to air pollution in the ZMG is the growth of the vehicle fleet (often old and poorly maintained). Industrial complexes, brick kilns (burning synthetic fuels), deforestation and agricultural burning also contribute.

The ZMG has a high annual average of days with excessive air pollution (up to 150 days of poor air quality per year have been reported). Pollutant levels often exceed local and international standards, including those of the World Health Organisation (WHO).

Methodology

The Jalisco Institute of Forensic Sciences (IJCF) was asked to facilitate the observation of samples of main bronchi, first branches, or pulmonary alveoli using SEM technology to search for the presence of particles. The samples were analysed at their facilities and preserved in 2% glutaraldehyde in 1.5 ml Eppendorf tubes.

The sample size was half a square centimetre. The specimens observed corresponded to individuals who had not presented chest injuries and had a low degree of decomposition. A total of 11 individuals who died in 2014 were observed.

Dehydration processes were applied with serial ethanol:

1. Ethanol 40% 1 hour
2. Ethanol 50% 1 hour
3. Ethanol 60% 1 hour
4. Ethanol 70% 1 hour
5. Ethanol 80% 1 hour
6. Ethanol 90% 1 hour
7. Ethanol 100% 1 hour (2x).

Finally, the samples were dried at critical point using Tousimis Samdri 795 equipment. This was the process used to prepare the samples for EDS analysis with Jeol JSM 6610LV equipment, operating at 10kV, with an Oxford Xmax EDS detector and Oxford AZtec software. Observation under the scanning electron microscope was performed with a secondary electron detector. A scanning electron microscopy sample holder was used for mounting, on a double-sided carbon tape substrate. The samples were coated with conductive material (99.9% gold) by sputtering with Denton Vacuum equipment.

Results

The samples were observed using scanning electron microscopy and elemental mapping analysis, identifying coarse, fine and ultrafine metal particles in human bronchi and lung tissue, as well as fragments of cement, plastic, yeast and bacteria. The similarity between the metal particles identified in the collected samples and those observed in lung tissue warns of latent risks to human health.

The main blood cells observed were erythrocytes, leukocytes, macrophages and platelets. Erythrocytes are the most abundant blood cells in the blood; they are biconcave discs with a diameter of between 6 and 8 μm and a thickness of 2 μm (Jaime *et al.*, 2009). Leukocytes are a group of cells that perform various functions, all related to the body's defence against infections and the presence of foreign substances. They are large cells that are classified as granulocytes, lymphocytes, and monocytes. Monocytes are large cells with a diameter of 15 to 20 μm . These cells travel through the blood and reach the connective tissue, where they become macrophages (González de Buitrago, 2010). Platelets are thin discs with a diameter of 2 to 4 μm . They participate in homeostasis, in maintaining vascular integrity and in the blood coagulation process (Conny *et al.*, 2011).

Subsequently, through EDS elemental mapping, some elements were identified per individual. The samples with the highest number of elements were individuals 1 and 9 with 12 elements, individuals 4 and 11 with 10 elements, individuals 3 and 12 with 9 elements, individuals 5 and 6 with 8 elements each, individual 2 with 7 elements, and individuals 7 and 10 with 5 elements. The most abundant elements were Al, Pb, As, Hg, and W. The least abundant were Zn, Ta, Nb, Hf, Cu, and Rh (Table and graph 1).

Box 1

Table 1

Descriptive statistics of the samples

Statistician	Value	Features
Population	11 Individuals	11 samples.
Range	12-5=7 elements	The difference between the largest and smallest samples is 7 elements.
Maximum	12 elements	Individuals 1 and 9 had the highest number of items.
Minimum	5 elements	Individuals 7 and 10 had the fewest items.
Average	8.82 elements	On average, each sample contained approximately 9 elements.

Source: Prepared internally based on research results

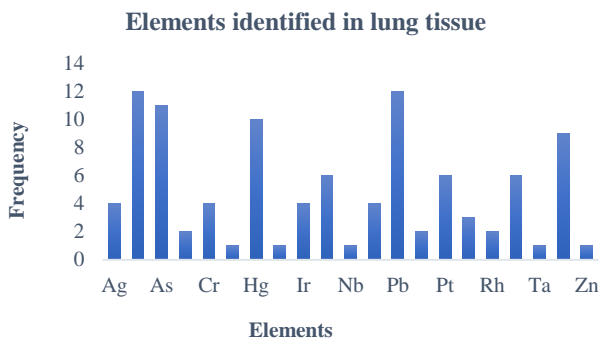
Box 2**Figure 1**

Elements identified per individual in lung tissue

Source: Prepared by the author based on research results

Once metal nanoparticles cross the lung barrier and reach the bloodstream, they can be distributed to virtually any organ in the body. This systemic dissemination is the cause of a wide range of adverse health effects that go beyond the respiratory system, affecting vital systems such as the cardiovascular and renal systems, and increasing the risk of chronic diseases such as cancer (Hamra, G. B. *et al.* 2014).

The study by Díaz-Gay *et al.* (2025) discusses the genomic mechanisms of lung cancer in non-smokers. The research showed that exposure to high levels of air pollution from PM_{2.5} particles is associated with an increase in somatic mutations, specifically the SBS4 and SBS5 mutational signatures. This finding is of utmost importance, as the SBS4 mutational signature had been associated almost exclusively with genetic damage caused by tobacco. Its presence in non-smokers exposed to air pollution suggests a mutation mechanism and challenges previous models of the causes of lung cancer. This same marker also highlights that there is an association between the accumulation of DNA damage with ageing and exposure.

Conclusions

The presence of these elements indicates a significant level of pollution in the environment, in addition to the fact that the body's ability to absorb, distribute and excrete these metals varies between individuals.

The metal particles identified in the samples collected and those observed in lung tissue warn of latent risks to human health.

We can infer that when heavy metals are found in the lung, the main route of entry was the air (dust, fumes, aerosols). This has direct implications for health. Chronic exposure to lead (Pb), arsenic (As) and mercury (Hg) through inhalation is associated with pulmonary fibrosis, inflammation, damage to the alveoli and risk of lung cancer (especially arsenic). In the case of tungsten (W), dust from this element has been associated with interstitial lung disease and fibrosis. Its presence alongside other metals suggests a common source of dust or fume contamination.

In general terms, Al, Pb, As, Hg and W are causing the direct toxic load on the respiratory system of the tissues observed.

Possible causes could include waste burning, industrial processes, smelter emissions, or dust particles raised by erosion, mining, or brickworks. It should be remembered that, due to their small size, NPs are deposited deep in the pulmonary alveoli and can even travel into the bloodstream, spreading to other organs.

Table 2 shows the elements identified in the samples and the possible health effects that may occur.

Box 3**Table 2**

Identified elements and possible health effects

Element	Main Source of Toxicity	Specific Health Issues
Lead (Pb)	Neurotoxicity and accumulation.	Damage to the central nervous system (mainly in children), hypertension, anaemia, and chronic renal failure.
Arsenic (As)	Known carcinogen.	Lung, bladder, and skin cancer. It affects the cardiovascular system and can cause neuropathy.
Mercury (Hg)	It vaporises and passes through barriers.	Neurotoxicity (tremors, cognitive impairment), kidney damage, and effects on foetal development.
Aluminium (Al)	Irritation and pulmonary fibrosis.	It may cause pneumoconiosis (aluminosis lung disease) after prolonged exposure to high doses, which may affect lung function.

Tungsten (W)	Carcinogenic potential.	Its toxicity has been less studied, but it has been associated with carcinogenic potential and pulmonary and renal toxicity in occupational studies.
Chrome (Cr)	Carcinogenic (Hexavalent Chromium).	Lung cancer, respiratory tract irritation, and contact allergies.
Copper (Cu)	Induction of oxidative stress.	In high concentrations, it can damage the liver and kidneys, as well as irritate the respiratory tract.
Cinc (Zn)	Metal fume fever.	Although essential, inhalation of ZnO NPs can cause "metal fume fever" and oxidative stress.
Platinum Group Metals (Pt, Rh, Os, Re)	Sensitisation and irritation.	Associated with occupational allergies and asthma, mainly in refinery workers or those working near catalytic converters. (by Pt and Rh).

Source: (EPA 2017; ATSDR 2016e; Royal Society of Chemistry 2017; Lennotech 2016; QuimiNet.com 2011)

It is important to note that NPMs act as vehicles for metals whose carcinogenicity is well defined. Hexavalent chromium (VI) and nickel, common components in the welding fumes mentioned above, are classified by the International Agency for Research on Cancer (IARC) as Group 1 carcinogens (carcinogenic to humans).

Some of the main roads in the ZMG have high traffic flow, which circulates constantly and is associated with an increased risk of respiratory diseases and lung cancer. There are criteria that indicate that a range of 4,000 to 10,000 vehicles per day is a common threshold for considering a road to be high-volume and, therefore, a significant source of pollution from particulate matter (PM_{2.5}) and metal nanoparticles, such as those generated by brake and tyre wear and exhaust fumes. Therefore, the risk of developing lung cancer and other respiratory diseases increases significantly when living within a radius of 300 to 500 metres of roads that exceed these high traffic flow thresholds (Querol, 2008; Raaschou-Nielsen *et al.*, 2013; Jerrett *et al.*, 2013).

Declarations

Conflict of interest

The authors declare that they have no conflict of interest. They have no known competing financial interests or personal relationships that could have appeared to influence the article reported in this paper.

Contribution of authors

Peña García Laura Elizabeth Contributed to the project idea, research method and technique.

Availability of data and materials

The data obtained in this research are available.

Funding

The research received funding for its development from P3E programmes.

Acknowledgements

I am forever grateful to the people who made it possible to complete this work (my colleagues).

Abbreviations

NPs	Nanoparticles
MP	Particulate material
PM _{2.5}	Particles with a diameter smaller than 2.5 µm
PM _{0.1}	Particles with a diameter smaller than 0.1 µm
PM ₁₀	Particles with a diameter smaller than 10 µm
NPM	Metal nanoparticles
ENT	Non-communicable diseases
EPOC	Chronic obstructive pulmonary disease
ZMG	Guadalajara metropolitan area
IARC	Cancer research
SLP	Sierra La Primavera
Ma	Millions of years

References

Background

Andujar, P., Valero, T., Ruz, P., & Rodríguez-Gómez, J. M. (2018). Revisión Sistemática sobre los efectos tóxicos de las nanopartículas metálicas en la salud de los trabajadores. *Revista Española de Salud Pública*, 92, 5 de septiembre. https://scielo.isciii.es/scielo.php?script=sci_arttext&pid=S0465-546X2018000300295

ATSDR. 2001. "Resumen de salud pública Cobalto (Cobalt)." *División de Toxicología y Ciencias de La Salud*, 1–9. https://www.atsdr.cdc.gov/es/phs/es_phs33.html

Centro Nacional de Investigaciones Oncológicas (CNIO). (2025, 2 de julio). *Los daños en el ADN derivados de la contaminación atmosférica podrían contribuir al cáncer de pulmón en personas no fumadoras, halla un estudio.* <https://www.cnio.es/noticias/los-danos-en-el-adn-derivados-de-la-contaminacion-atmosferica-podrian-contribuir-al-cancer-de-pulmon-en-personas-no-fumadoras-halla-un-estudio/>

Corona Sánchez, J. E., González Chávez, M. del C. A., Carrillo González, R., Scheckel, K., Tapia Maruri, D., & García Cue, J. L. (2021). Metal(loid) bioaccessibility of atmospheric particulate matter from mine tailings at Zimapán, Mexico. *Environmental Science and Pollution Research*, 28(15), 19458–19472. <https://doi.org/10.1007/S11356-020-11887-6/FIGURES/5>

Díaz-Gay, M., Zhang, T., Hoang, P. H., Leduc, C., Baine, M. K., Travis, W. D., Sholl, L. M., Joubert, P., Khandekar, A., Zhao, W., Steele, C. D., Otlu, B., Nandi, S. P., Vangara, R., Bergstrom, E. N., Kazachkova, M., Pich, O., Swanton, C., Hsiung, C. A., ... Landi, M. T. (2025). The mutagenic forces shaping the genomes of lung cancer in never smokers. *Nature*, 644(8075), 133–144. <https://pubmed.ncbi.nlm.nih.gov/40604281/>

Fu, P. P., Xia, Q., Hwang, H. M., Ray, P. C., & Yu, H. (2014). Mechanisms of nanotoxicity: Generation of reactive oxygen species. *Journal of Food and Drug Analysis*, 22(1), 64–75. <https://doi.org/10.1016/j.jfda.2014.01.005>

García-Torra, V., Cano, A., Espina, M., Ettcheto, M., Camins, A., Barroso, E., Vazquez-Carrera, M., García, M. L., Sánchez-López, E., & Souto, E. B. (2021). State of the Art on Toxicological Mechanisms of Metal and Metal Oxide Nanoparticles and Strategies to Reduce Toxicological Risks. *Toxics* 2021, Vol. 9, Page 195, 9(8), 195. <https://doi.org/10.3390/TOXICS9080195>

Garnica Ibarra, Lucía Guadalupe, Roberto Maciel Flores, Edith Xio Mara García García, Miguel Ángel Alatorre Zamora, and Laura Elizabeth Peña García. 2017. "Análisis geológico - geofísico para delimitar zonas de recarga de acuíferos, Aplicación: Zona Perimetral de Guadalajara." Universidad de Guadalajara. <https://www.riudg.udg.mx/handle/20.500.12104/73553?mode=full>

Geraldo, L. J. V.-D. R., & Juárez-Moreno Karla. (2022, August 15). *Desbalance del sistema antioxidante causado por la exposición a nanopartículas de óxido de zinc y óxido de cobre.* <https://doi.org/10.22201/ceiich.24485691e.2022.29.69701>

Gutiérrez González, L., José Hernández Jiménez, M., Borchert, L. M., Molina Borchert, L., Leonor, C., & Borchert, M. (2013). Daños para la salud tras exposición laboral a nanopartículas. *Medicina y Seguridad Del Trabajo*, 59(231), 276–296. <https://doi.org/10.4321/S0465-546X2013000200007>

Ellwanger, J. H., Ziliotto, M., & Chies, J. A. B. (2025). Lung Deposition of Particulate Matter as a Source of Metal Exposure: A Threat to Humans and Animals. *Toxics*, 13(9), 788. <https://doi.org/10.3390/toxics13090788>

Hamra, G. B., Guha, N., Cohen, A., Laden, F., Raaschou-Nielsen, O., Samet, J. M., Vineis, P., Forastiere, F., Saldiva, P., Yorifuji, T., & Loomis, D. (2014). Outdoor Particulate Matter Exposure and Lung Cancer: A Systematic Review and Meta-Analysis. *Environmental Health Perspectives*, 122(9), 906–911. <https://pubmed.ncbi.nlm.nih.gov/24911630/>

Min, Y., Suminda, G. G. D., Heo, Y., Kim, M., Ghosh, M., & Son, Y-O. (2023). Metal-Based Nanoparticles and Their Relevant Consequences on Cytotoxicity Cascade and Induced Oxidative Stress. *Antioxidants*, 12 (3), 703. <https://doi.org/10.3390/antiox12030703>

Montero, M. Á., de Gracia, J., & Morell, F. (2010). Enfermedad pulmonar intersticial por metales duros. *Archivos de Bronconeumología*, 46(9), 489–491. <https://doi.org/10.1016/J.ARBRES.2009.10.007>

Jerrett, M., Burnett, R. T., Pope, C. A., III, Ito, K., Lowcock, G. A., Anderson, H., Turner, M. C., Krewski, D., Arden Pope, C., Krewski, D., Al-Alem, E., & (2013). Long-term association of outdoor air pollution and cause-specific mortality. *New England Journal of Medicine*, 368(1), 74–81. <https://pubmed.ncbi.nlm.nih.gov/19279340/>

Jiménez-Barrios, N., & Chirino, Y. I. (2018). ¿Los nanomateriales pueden causar neurotoxicidad? *Mundo Nano. Revista Interdisciplinaria En Nanociencias y Nanotecnología*, 11(20), 17–26. <https://doi.org/10.22201/CEIICH.24485691E.2018.20.64118>

Lenntech. n.d. “Cromo (Cr) Propiedades químicas y efectos sobre la salud y el medio ambiente.” Accessed April 22, 2019. <https://www.lenntech.es/periodica/elementos/cr.htm>

Navarro Espinoza, S., Meza-Figueroa, D., Soto-Puebla, D., Castañeda, B., & Pedroza-Montero, M. (2021). Nanopartículas: Efectos en la salud humana y el medio ambiente. *Epistemus*, 15(30). <https://epistemus.unison.mx/index.php/epistemus/article/view/166>

Querol, Xavier. 2008. “Calidad del aire, partículas en suspensión y metales.” *Revista Española de Salud Pública* 82 (5): 447–53. <https://doi.org/10.1590/S1135-57272008000500001>

Royal Society of Chemistry. 2017. “Periodic Table.” Royal Society of Chemistry. 2017. <http://www.rsc.org/periodic-table>

Essentials

EPA. 2017. “Initial List of Hazardous Air Pollutants with Modifications.” Hazardous Air Pollutants. 2017. <https://www.epa.gov/haps/initial-list-hazardous-air-pollutants-modifications#mods>

González de Buitrago, José Manuel. 2010. *Técnicas y métodos de laboratorio clínico*. 3a edición. Barcelona: Elsevier Masson. <https://www.sciencedirect.com/book/monograph/9788445820292/tecnicas-y-metodos-de-laboratorio-clinico#book-info>

Maciel Flores, Roberto, and José Rosas Elguera. 1992. “Modelo geológico y evaluación del campo geotérmico La Primavera, Jal., México.” *Geofísica Internacional* 31 (4): 359–70. <https://revistagi.geofisica.unam.mx/index.php/RGI/article/view/1352>

Peña García, L. E. (2019). *Partículas ultrafinas ambientales en el área metropolitana de Guadalajara, México* [Biblioteca Digital wdg.biblio]. <https://www.riudg.udg.mx/handle/20.500.12104/82166>

Santana Báez, S., Mendoza Martín, M., Quevedo Villegas, M. C., Gutiérrez Disla, E. J., Santana Báez, S., Mendoza Martín, M., Quevedo Villegas, M. C., & Gutiérrez Disla, E. J. (1952). Revisión Sistemática sobre los efectos tóxicos de las nanopartículas metálicas en la salud de los trabajadores. *Medicina y Seguridad Del Trabajo*, 64(252), 295–311. https://scielo.isciii.es/scielo.php?script=sci_artext&pid=S0465-546X2018000300295&lng=es&nrm=iso&tlng=es

Torre-Bouscoulet, L., Aguilar-Madrid, G., & Palomeque-Ceballos, N. (2013). Daños para la salud tras exposición laboral a nanopartículas. *Revista Española de Salud Pública*, 87(2), 177–187. https://scielo.isciii.es/scielo.php?script=sci_artext&pid=S0465-546X2013000200007

Noticias ONU. (2024, junio). *La contaminación atmosférica causó 8,1 millones de muertes en todo el mundo en 2021*. <https://news.un.org/es/story/2024/06/1530631>

Organización Mundial de la Salud (OMS). (2021). *Las nuevas Directrices mundiales de la OMS sobre la calidad del aire tienen como objetivo evitar millones de muertes debidas a la contaminación del aire*. [Comunicado de prensa]. <https://www.who.int/es/news/item/22-09-2021-new-who-global-air-quality-guidelines-aim-to-save-millions-of-lives-from-air-pollution>

Raaschou-Nielsen, O., Andersen, Z. J., Beelen, R., Samoli, E., Stafoggia, M., Weinmayr, G., Hoffmann, B., Fischer, P., Meliefste, M., Sovcikova, E. & Hoek, G. (2013). Air pollution and lung cancer incidence in 17 European cohorts: Prospective data from ESCAPE. *The Lancet Oncology*, 14(9), 813-822. [https://doi.org/10.1016/S1470-2045\(13\)70279-1](https://doi.org/10.1016/S1470-2045(13)70279-1)

Ruiz-Ocampo, P. E., Larrubia-Salazar, M. J., García-Martínez, M. J., & Romero-Quezada, L. G. (2018). ¿Los nanomateriales pueden causar neurotoxicidad? *Mundo Nano. Revista Interdisciplinaria en Nanociencias y Nanotecnología*, 11(20), 17-30. https://www.scielo.org.mx/scielo.php?script=sci_arttext&pid=S2448-56912018000100017

Velasco, M. (2009). Enfermedad pulmonar intersticial por metales duros. *Archivos de Bronconeumología*, 45(11), 549-557. <https://www.archbronconeumol.org/es-enfermedad-pulmonar-intersticial-por-metales-articulo-S0300289609004256>

Vargas Marcos, Francisco. (2005). La contaminación ambiental como factor determinante de la salud. ” *Revista Española de Salud Pública* 79(2): 117–27. http://scielo.isciii.es/scielo.php?script=sci_arttext&pid=S1135-57272005000200001&lng=es&tlng=es

Support

Conny, Joseph M., and Gary A. Norris. 2011. “Scanning Electron Microanalysis and Analytical Challenges of Mapping Elements in Urban Atmospheric Particles.” *Environmental Science and Technology* 45 (17): 7380–86. <https://doi.org/10.1021/es2009049>

Díaz-Gay, M., Zhang, T., Hoang, P. H., *et al.* (2025). The mutagenic forces shaping the genomes of lung cancer in never smokers. *Nature*, 644(8075), 133-144. DOI: 10.1038/s41586-025-09219-0. <https://pubmed.ncbi.nlm.nih.gov/40604281/>

Jaime, C., Pérez, N., & Ruiz, M. (2009). *Hematología: Fisiología de la sangre y sus componentes* (2.^a ed.). Ediciones Médicas del Cono Sur. https://aulavirtualcbj.com.ar/wp-content/uploads/2024/11/Hematologia_Jaime_Perez_2ed.pdf

Querol, Xavier. 2008. “Calidad del aire, partículas en suspensión y metales.” *Revista Española de Salud Pública* 82 (5): 447–53. <https://dialnet.unirioja.es/servlet/articulo?codigo=2735981>

Raaschou-Nielsen O, Andersen ZJ, Beelen R, Samoli E, Stafoggia M, Weinmayr G, Hoffmann B, Fischer P, Nieuwenhuijsen MJ, Brunekreef B, Xun WW, Katsouyanni K, Dimakopoulou K, Sommar J, Forsberg B, Modig L, Oudin A, Oftedal B, Schwarze PE, Nafstad P, De Faire U, Pedersen NL, Ostenson CG, Fratiglioni L, Penell J, Korek M, Pershagen G, Eriksen KT, Sørensen M, Tjønneland A, Ellermann T, Eeftens M, Peeters PH, Meliefste K, Wang M, Bueno-de-Mesquita B, Key TJ, de Hoogh K, Concin H, Nagel G, Vilier A, Grioni S, Krogh V, Tsai MY, Ricceri F, Sacerdote C, Galassi C, Migliore E, Ranzi A, Cesaroni G, Badaloni C, Forastiere F, Tamayo I, Amiano P, Dorronsoro M, Trichopoulou A, Bamia C, Vineis P, Hoek G. Air pollution and lung cancer incidence in 17 European cohorts: prospective analyses from the European Study of Cohorts for Air Pollution Effects (ESCAPE). *Lancet Oncol.* 2013 Aug;14(9):813-22. doi: 10.1016/S1470-2045(13)70279-1. Epub 2013 Jul 10. PMID: 23849838. <https://pubmed.ncbi.nlm.nih.gov/23849838/>

Learning analytics with CAD traces and predictive models: Reliability and performance

Analítica de aprendizaje con trazas CAD y modelos predictivos: Confiabilidad y desempeño

Corral-Verdugo, Alex^{*a}, Sepúlveda-Romo, Adrián^b, Jimenez-Lopez, Eusebio^c and León-Rochin, German^d

^a Universidad Tecnológica del sur de Sonora / Universidad La Salle Noroeste • ODI-7910-2025 • 0009-0002-7645-9857 • 072915

^b Universidad Tecnológica del sur de Sonora • OJT-1262-2025 • 0000-0002-7639-3512 • 2072915

^c Instituto Tecnológico Superior de Cajeme / Universidad La Salle Noroeste • 0000-0001-6893-3550 • 66512

^d Universidad Tecnológica del sur de Sonora • OQK-6272-2025 • 0000-0002-0120-7922 • 1265462

Classification:

Area: Social Sciences and Humanities
Field: Education
Discipline: Education
Subdiscipline: Comparative Education

<https://doi.org/10.35429/JTD.2025.9.22.3.1.13>

History of the article:

Received: January 13, 2025

Accepted: November 10, 2025

* [\[acorral@uts.edu.mx\]](mailto:acorral@uts.edu.mx)



Abstract

This study gives us a proposal and validation of a trace-based evaluative framework for CAD courses in technical education. It integrates entry predictors (CAD pretest and spatial ability), process logs (operations, errors, undo actions, latencies and fully defined sketches), and rubric-based scoring to offer instruction-sensitive formative feedback. With 60 students under a crossed AB/BA design (120 observations), we estimated inter-rater reliability and predictive models. Consistency was high ($\alpha = .915$; $ICC = .849/.919$) and there was no systematic bias between evaluations ($t(23) = -0.02$, $p = .986$; Bland–Altman). Performance was explained mainly by the CAD pretest, with additional contribution from spatial ability; E1 and E2 correlated strongly ($r = .85$). The study showed sequence-differential attrition ($p = .006$) which did not present selection bias. The study offers a replicable protocol and metrics that can be used by any instructor, promoting more efficient and equitable assessment decision-making.

Resumen

El presente estudio describe una propuesta y validación de un marco evaluativo basado en trazas para cursos de CAD (Computer Aided Desing) en educación técnica. Integra predictores de entrada (pretest de CAD y visión espacial), registros de proceso (operaciones, errores, deshacer y latencias, bocetos definidos) y calificación por rúbrica para ofrecer retroalimentación formativa sensible a la instrucción. Con 60 estudiantes bajo un diseño cruzado AB/BA (120 observaciones), se estimó la confiabilidad interevaluador y los modelos predictivos. La consistencia fue alta ($\alpha = .915$; $ICC = .849/.919$) y no hubo sesgo sistemático entre evaluaciones ($t(23) = -0.02$, $p = .986$; Bland–Altman). El desempeño se explicó principalmente por el pretest de CAD, con aporte adicional de la visión espacial; E1 y E2 se correlacionaron fuertemente ($r = .85$). En el estudio existió atrición diferencial por secuencia ($p = .006$) la cual no presentó sesgo de selección. El estudio ofrece un protocolo replicable y métricas las cuales pueden ser utilizadas por cualquier docente, promoviendo toma de decisiones evaluativas más eficientes y equitativas.

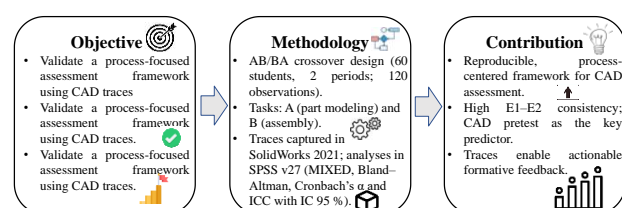

CAD learning analytics; process traces

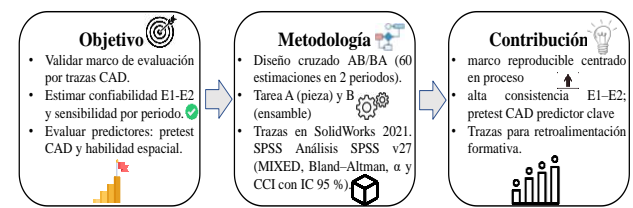

CAD, analítica del aprendizaje, trazas de proceso

Area: Development of strategic leading-edge technologies and open innovation for social transformation.

Citation: Corral-Verdugo, Alex, Sepúlveda-Romo, Adrián, Jimenez-Lopez, Eusebio and León-Rochin, German. [2025]. Development of strategic leading-edge technologies and open innovation for social transformation. Journal of Technological Development. 9 [22] 1-13; e30922113



ISSN 2531-2960/© 2009 The Authors. Published by ECORFAN-México, S.C. for its Holding Spain on behalf of Journal of Technological Development. This is an open-access article under the license CC BY-NC-ND license [<http://creativecommons.org/licenses/by-nc-nd/4.0/>]

Peer review under the responsibility of the Scientific Committee MARVID® in the contribution to the scientific, technological and innovation Peer Review Process through the training of Human Resources for the continuity in the Critical Analysis of International Research.



Introduction

In recent years, computer-aided design (CAD) has served as a central element in technical and engineering training. This enables geometric representation, articulation and collaboration, iteration and feedback throughout the entire creation and design process. Therefore, it is important to focus not only on the final product, but also on the process that students follow when creating their models (Bojčetić *et al.*, 2021; Contero *et al.*, 2023; Xie *et al.*, 2014).

In large populations, manual assessment becomes costly and diverse, which is why there are proposals for automated assessment and learning analytics approaches that provide in-depth, timely and effective feedback (Eltaief *et al.*, 2024; Jaakma and Kiviluoma, 2019; Company *et al.*, 2015).

Approaching an assessment process using a 3D model through learning analytics provides great value that is applicable both theoretically and methodologically. In this way, it converges as a scaffolding that is capable of interpreting process data and closing the feedback loop through learning dashboards and continuous improvement frameworks focused on learning, provided that instructional design guides capture, interpretation, and action (Wang, 2021; Sailer *et al.*, 2024; Paulsen and Lindsay, 2024; Susnjak *et al.*, 2022; Anghel *et al.*, 2024). Applying all these principles to the CAD context is natural when performing sequences of sketching, editing, commands such as undo/redo, and design regenerations.

It is time-based analytics with a design focus that allows difficulties to be anticipated and specific support to be provided at the most opportune moment (Wang, 2021; Sailer *et al.*, 2024).

Speaking specifically about the field of CAD design, empirical evidence suggests that traces are related to the instruction given. Some pedagogical adjustments provided outside the design software leave certain detectable traces or footprints in action patterns within the tool used, and all this enables estimation during the process and not only at the end of it (Xie *et al.*, 2014).

Similarly, progress has been made in proposals for visual analytics and formative feedback that explore the structure of the entire record of the parametric models created, in order to detect all the deficiencies that arose during the construction of the model, with a view to guiding more timely and accurate pedagogical interventions (Otto & Mandorli 2021; Mandorli, & Otto, 2024; Otto & Mandorli, 2025). This is why the evaluation process moves from individual geometric verification to an explicit assessment of the strategy for constructing and modifying the model to be created, in addition to dimensions that can be inferred from the traces and history of all the parametric operations performed (Contero *et al.*, 2023; Aranburu *et al.*, 2023; Zou *et al.*, 2023).

Several recent studies suggest lines of research that help strengthen the evaluation process. Firstly, the application of self-assessment tools, which provide verification of both geometric accuracy and design intent, offers promising results in higher-level courses by allowing the robustness of the applied model to be estimated in the face of parametric changes and reducing the workload for the teacher (Jaakma and Kiviluoma, 2019).

Secondly, the application of coordinated rubrics that formalise quality criteria for all parametric modelling carried out, as well as generating a logical order of operations used, in addition to the complete definition of sketches, nomenclature and the current capacity for modification in designs, which places teaching alongside assessment and provides greater consistency between different assessors (Company *et al.*, 2015).

Thirdly, there are adjustable multi-criteria tools that weigh geometric dimensions, based on operations and parameters in accordance with very specific teaching objectives, which present recent improvements in both precision and flexibility (Eltaief *et al.*, 2024; Nobes, 2025). These lines aim to scale the grade obtained, reduce any type of bias and, above all, offer an approach to assessment and how it is modelled in student practice (Bojčetić *et al.*, 2021).

It is necessary to consider that the performance shown by students in CAD is not solely a consequence of their performance with this tool.

Measurement using individual predictors is key to correctly interpreting the results. Similarly, prior knowledge shows high stability between measurements and its relationship with learning, although this relationship varies depending on the context. It also functions as a fundamental covariate when analysing instructional effects (Simonsmeier *et al.*, 2022). Similarly, spatial ability is associated with performance in design graphics and CAD courses and can be developed through specific instruction.

Recent reviews on the evaluation of technical sketches and the use of immersive environments support the relevance of considering these variables in course design (Bartlett & Camba, 2023; Dilling & Vogler, 2021; Gittinger & Wiesche, 2024; Merzdorf *et al.*, 2024; Zhu *et al.*, 2023). Consequently, the integration of these predictors with CAD traces allows us to explain the disparity that still exists depending on the different learning paths adopted, enabling us to focus timely support where it is needed (Dilling & Vogler, 2021; Merzdorf *et al.*, 2024; Riestra-González *et al.*, 2021; Sailer *et al.*, 2024; Simonsmeier *et al.*, 2022; Wang, 2021). Even with all this, there are significant gaps in real classroom environments. Despite the various solutions that exist, these prioritise product metrics such as geometric matching, operation counting and, more recently, the incorporation of more flexible forms such as construction and modification capacity as weighted criteria (Eltaief *et al.*, 2024; Company *et al.*, 2015).

However, there are very few studies that combine a quasi-experimental classroom design with task counterbalancing, analysis of process traces, and the management and use of rubrics as an assessment process (Otto & Mandorli, 2021; Mandorli, & Otto, 2024; Nobes, 2025). It is also worth mentioning the lack of evidence in upper secondary technical education, due to the large cohorts involved, time constraints, and the need for reproducible, scalable, and economical methods (Bojčetić *et al.*, 2021).

This work evaluates the feasibility of using CAD software traces as an assessment method in SolidWorks part construction and assembly tasks, integrating three components: 1) process metrics per session, 2) product ratings, and 3) individual predictors.

Input predictors such as CAD pretest, spatial ability, process traces, and product performance are added to facilitate more comprehensive formative feedback (see Figure 1). In particular, operations per minute, milliseconds per operation, proportion of fully defined sketches, undo options per minute, errors per minute, and total time are analysed. Two product evaluations at different times (E1 and E2) were considered, and the CAD pretest and spatial ability were incorporated as covariates.

This was achieved through a cross-over design with counterbalancing by task. In addition, we studied whether the traces capture instructional differences between periods, the consistency and absence of bias in the evaluation, and the additional explanatory power of the predictors on the performance shown.

This provides three elements: 1) a replicable framework for implementing CAD courses with trace-based assessment, 2) evidence on which process metrics are most informative for formative feedback, and 3) guidelines for integrating rubrics, assisted self-assessment, and learning analytics dashboards into CAD, all of this in line with closed-loop frameworks considering the instructional sensitivity offered by traces (Sailer *et al.*, 2024; Paulsen and Lindsay, 2024; Susnjak *et al.*, 2022; Xie *et al.*, 2014).

This study is highly relevant because it is firmly rooted in Mexican technical education, where the curricula of institutions such as DGETI and CONALEP incorporate computer-aided design, modelling and drawing (CAD) modules in mechatronics and related areas. That is why CAD skills form the basis of a key curricular competency in student training (SEMS–COSFAC, n.d.; CONALEP, 2023).

In the productive sphere, there is great external relevance, as this is supported by the demand for talent in the country's manufacturing and aerospace sectors, with constant contributions to employment and production, thus creating an evident need for human capital specialised in these technical areas that are necessary in the country (INEGI, 2025; Secretaría de Economía, 2020).

Box 1

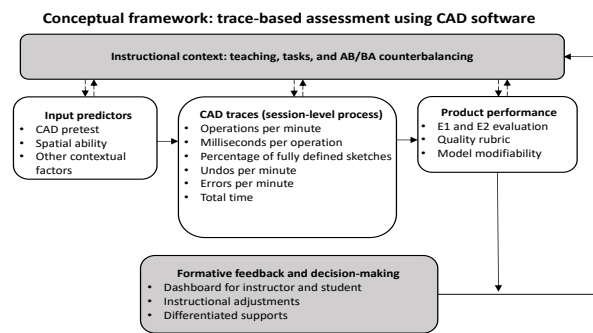

Figure 1

Conceptual framework for CAD trace-based assessment. The main flow goes from input predictors to process traces, then to product performance, and finally to formative feedback; the dashed lines indicate the sensitivity and influence of instruction on the process.

Source: Own Elaboration

Methodology

Participants and context

Sixty mechatronics students (technical degree programme at upper secondary level) participated, of whom 30 were from the morning shift (3A-MEC) and 30 from the afternoon shift (3B-MEC). In both shifts, the sequence was balanced into two groups of 15 people: AB (task A first and then task B) and BA (task B first and then A). Participation was curricular, and the data was anonymised with alphanumeric identifiers for all participants (M01–M30, V01–V30).

Unit of analysis

Although the unit of analysis consisted of 60 students (30 morning, 30 afternoon), each student completed two periods (P1 and P2). Therefore, in the analyses at the student level per period, 120 analytical observations (60×2) were used. It should be noted that in the Results section, $n=120$ refers to the observations (P1+P2) and not to the number of students.

Research design

An AB/BA crossover design was used, considering two non-contiguous periods: Period 1 (P1) in week 1 and Period 2 (P2) in week 3. Week 2 was reserved as an exposure-free interval to minimise residual effects between periods. The design allows for the estimation of task effects (A vs. B), period and sequence with intra-subject control (see Figure 2).

Box 2

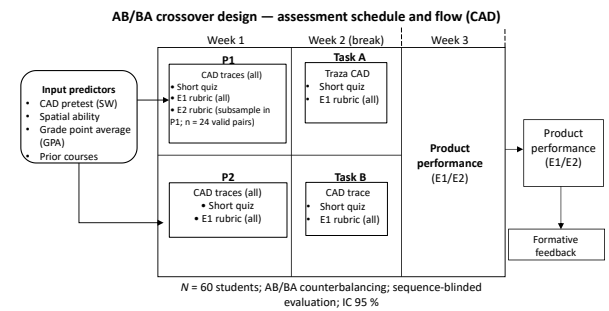

Figure 2

AB/BA cross-over design — schedule and evaluation flow (CAD)). In P1 and P2, alternating tasks are applied according to the sequence (AB or BA). In each period, CAD traces are captured, the short test is applied, and it is graded with E1 (and E2 only in a subsample of P1). $N = 60$ students; AB/BA counterbalancing; sequence-blinded assessment; 95% CI.

Source: Own Elaboration

Allocation and blinding

Assignment to sequences AB and BA was carried out in a stratified manner by shift until 15 students per sequence were completed in each shift. The assignment list was generated before the start and was kept blind or hidden from those who graded the products, in order to avoid influencing the grading. The subsample of 30 students (50%) for the second assessor's (E2) grading was selected at random, stratified by shift (15 morning and 15 afternoon), maintaining overall parity by sequence (AB and BA), and was applied during period 1 (P1).

Tasks and materials

- **Task A (part):** parametric modelling of a part with an emphasis on creating fully defined sketches and modelling operations.
- **Task B (part):** parametric modelling of a part with an emphasis on creating fully defined sketches and modelling operations.

Environment, software, and hardware

The sessions were conducted in SolidWorks 2021 (Dassault Systèmes) on Windows 10 Pro, Dell desktop workstations, Intel Core i5-5200U CPU, 8 GB DDR3 RAM, ≥ 240 GB SSD, integrated GPU, 24" 1920×1080 monitor, and 3-button mouse.

All these resources were sufficient for the planned CAD educational tasks; dedicated GPU acceleration and advanced rendering features were not used.

Obtaining and processing traces

Records or traces were obtained from the sequences generated by the software for each session, such as operations, reconstructions, undo commands, errors, and timestamps.

- **Export:** at the end of each session, the logs were exported to a CSV file per student-period, with local time zone.
- **Cleaning:** integrity (identifier or ID, chronology, duplicates) and units (millimetre, gram, second) were validated.
- **Computation:** the variables described below were summarised for each session.
- **Analytical repository:** a master file was consolidated in Excel and a syntax was prepared for SPSS v27 that allows all analyses to be reproduced.

Measures

Traces per session

The following were considered:

- Operations per minute, number of operations, number of sketches, percentage of defined sketches, number of position relationships, reconstruction time (seconds), milliseconds per operation, undo per minute, errors per minute, total time (minutes), idle time (minutes) and start of first trace (seconds).
- Interpretation: higher operations per minute and percentage of defined sketches reflect better workflow; lower milliseconds per operation, undo per minute, errors per minute, and idle time indicate smoother interaction with the tool.

Learning performance

- Rubric rating by the primary evaluator (E1, scale 0–100) applied to all analysed products.
- Rubric rating by a second evaluator (E2, scale 0–100) on a 50% subsample (30 students) in Period 1 (P1) balanced by shift (15 and 15) and with overall parity by sequence, to estimate inter-evaluator reliability.
- Short test (scale 0–100) specific to each task and period, applied at the end of each session.

Traceability of the analytical set for reliability and E1–E2 comparison

Of the planned subsample of 30 students with a second assessor's rating (E2) in P1, 24 cases met the analytical criteria (complete E1–E2 pairs with no missing values) and constituted the analytical set used for the estimation of reliability (CCI and α), the 'paired t-test' and the general linear model of repeated measures (within-subjects factor: measurement E1, E2; between-subjects factor: task in P1). The distribution by task in P1 was A=6 and B=18. This imbalance arose due to the exclusion from the complete list of some cases with missing data in E1 or E2; the planning maintained parity by shift and sequence, but only 24 pairs met the final analytical criteria.

Note on analytical counting

The main analysis with E1 uses 120 observations derived from 60 students measured in two periods (P1 and P2). Analyses with E2 are restricted to the subsample with complete pairs in P1 ($n = 24$) to emphasise that they are E1 + E2, as documented in the stated analytical traceability.

Differential attrition by sequence

The availability of E2 in P1 depended on the assigned sequence (AB/BA), with evidence of differential attrition ($p = .006$). Although comparability analyses showed no differences in baseline covariates between included vs. excluded cases, analyses with E2 are interpreted with caution and adjusted according to sequence.

Engagement (self-report based on traces)**A brief self-report (4 items, scale 1–7) was considered**

These items range from interest, attention, effort, and intention to continue, all of which were adapted and reviewed by expert judgement (three CAD teachers; 1 = strongly disagree, 7 = strongly agree).

Participation index (derived from traces)

Standardised scores (z) were averaged with positive orientation of: operations per minute, percentage of defined sketches, inverse of undo per minute, inverse of errors per minute, inverse of milliseconds per operation. Transformation [1] was applied. This transformation is applied in order to positively orient these metrics, interpreted as follows: if a lower original value is obtained, this would indicate better performance and a number of positional relationships in the assembly, with higher index values indicating greater fluidity.

Covariates

Four continuous measures were included to control for prior differences: diagnostic test of software use (SolidWorks) (0–100), spatial vision test (0–100), academic average (0–10), and prior courses in CAD/Industry 4.0 (count). All covariates were entered as continuous in their original scale in the models.

Risk label (only in P1)

An initial risk label (binary variable) was defined prior to analysis and assigned a value of 1 when any of the following conditions were met in Period 1 (P1, shown below); otherwise, a value of 0 was assigned:

- The E1 grade was in the 15th percentile or below of the P1 cohort;
- Errors per minute and downtime were both in the 85th percentile or higher (P1 cohort);
- There was a coincidence of tardiness and late delivery in the session;

- The student reported the intention to drop out; however, this rule is conservative and is therefore used as an early warning to guide specific support.

Procedure

Two sessions were considered for the evaluation, which were recorded as follows: P1 in week 1 and P2 in week 3. Week 2 was left as an interval without any exposure (no CAD activities) to reduce possible residual effects between periods. In each session, before starting, the preliminary tests were administered, and at the end, the short test and brief self-report of participation were administered, lasting approximately one minute. Product ratings were issued without the evaluators knowing the sequence assigned to the student. Each student generated two assessable products (one per period), so performance variables (e.g., E1) were also analysed at the student level for each period (120 observations). The E2 assessment was administered only in P1 to a planned subsample (30), of which 24 E1–E2 pairs (P1 subsample, $n = 24$) were valid.

Statistical analysis plan (SPSS v27)**1. Mixed linear models for E1.**

A model was fitted with fixed effects for sequence (AB/BA), period (P1/P2), their interaction, and shift, with a random intercept per student. In addition, the following will be included as continuous covariates: prior testing of software use, spatial vision testing, academic average, and previous courses taken. Estimates (marginal mean differences), standard errors, p -values, and 95% confidence intervals will also be reported, with subsequent comparisons adjusted for sequence interaction by period.

2. Inter-rater reliability.

The two-way intraclass correlation coefficient (ICC), mixed model, consistency type (95% CI) was estimated using the E1 and E2 scores of the planned subsample of 30 students in P1. The record of a sensitivity analysis with the absolute agreement ICC was also considered.

3. Logistic regression for risk label (P1 only)

The initial (binary) risk label will be the result and predictors such as: operations per minute, percentage of defined sketches, inverse of undo per minute, inverse of errors per minute, inverse of milliseconds per operation (function [1] was applied to these three metrics associated with corrections and interruptions), number of position relations, downtime, and latency to first stroke; in addition to the covariates considered (previous tests, average, and courses). Odds ratios (OR) with 95% CI, goodness of fit (including Hosmer–Lemeshow) and discriminatory performance using the area under the ROC curve (AUC) will also be reported. In addition, sensitivity and specificity will be reported at the optimal cut-off point determined by Youden's index) [2] together with the ROC curve, indicating the selected threshold and, where possible, 95% confidence intervals.

4. Assumptions and sensitivity analysis

- Multicollinearity. The variance inflation factor (VIF) was reviewed with a guideline threshold (< 5) and the condition number (< 30). If high collinearity is detected, centring/scaling predictors, reducing or combining variables will be considered.
- Linearity in the logit function (logarithm of the odds ratio). For continuous predictors, linearity in the logit will be verified, understood as [3] The Box–Tidwell test will be applied and, if there is evidence of non-linearity, restricted cubic splines or fractional polynomials will be considered.
- Influential observations. Standardised deviance residuals (absolute values > 3) and leverage will be inspected. Standardised deviance residuals (absolute values > 3) and leverage will be inspected. [4] stricter criterion [5] Cook's distance (strong signal > 1 , initial signal [6] in addition to DFBETAs (standardised change in each coefficient when removing a case; for example [7] where p is the number of model parameters in the linear predictor (including the intercept) and n is the number of cases analysed.

The cases flagged will be reviewed and any decision (to keep, transform or exclude) will be documented in the Annexes.

- Ablation by predictor groups: The regressions will be repeated, eliminating the trace variable families (flow/efficiency; corrections and interruptions; times) one by one, and compared with the complete model using the same sample. AUC (with 95% CI), sensitivity/specificity at the Youden cut-off point

$$J = \text{sensitivity} + \text{specificity} - 1 \quad [8]$$

and changes in odds ratios (OR) (magnitude, direction and 95% CI).

5. Missing data and outliers

The percentage of missing data per variable and the pattern of absence will be described (where applicable, Little's test will be used). If the data lost per variable is less than or equal to 5%, a complete list analysis will be performed in its entirety; if it exceeds 5%, multiple chained imputation will be applied (at least 20 imputations and 10 iterations for each set), including all analytical variables and auxiliary variables related to the absence in the imputation model. Imputations will be made on the original scale; transformations (e.g.) and standardisations (z) will be calculated after the aforementioned imputation has been performed. The results will be combined with Rubin's rules and compared with the complete list analysis to verify the robustness of the design.

Outliers previously defined as $|z| > 3.5$ will be inspected and any decision to keep, transform or exclude them will be documented in the Annexes. In logistic models, the review of deviance residuals, leverage, Cook's distance and DFBETAs will complement this criterion.

Attrition analysis in subsample E2. Within the 30 cases planned for the second evaluator's (E2) rating in P1, those included in the analytical set ($n = 24$, complete E1–E2 pairs) will be compared with those excluded ($n = 6$) in baseline covariates (SolidWorks pretest, spatial vision test, academic average, and previous courses).

The Student's t-test for independent samples (with Levene's correction) was used, and the Mann–Whitney test was used for sensitivity. In addition, as an additional method, the distribution by task (A/B) between those included and those excluded was compared. Finally, the absence of substantive statistical differences supported the conclusion that the reduction from 30 to 24 did not introduce any systematic bias.

6. Residual effects between periods (sensitivity)

To verify the absence of residual effects between periods, two sensitivity analyses were performed, which are:

- In P2, the effect of the sequence (AB versus BA) was compared as a test for possible residual effects.
- The main analysis was repeated restricted to P1, where there is no influence from a previous period.

Ethical considerations. The study complied with institutional educational ethics regulations. Institutional informed consent was obtained, the data were anonymised and used exclusively for academic purposes.

Transparency and availability

Transparency and availability. Anonymised CSV files, a master Excel file, SPSS v27 syntax and a variable dictionary were provided, along with a step-by-step reproduction guide. The materials will be deposited in a public repository and the link/DOI will be included in the final version.

Results

Analytical set

Of the 60 students considered (P1 and P2 = 120 observations), a double assessment (E1+E2) was planned for 30 samples in P1; 24 complete pairs were analysed (as 6 were excluded due to lack of E1 or E2). In P1, the distribution presented by task was A = 6 and B = 18.

Box 3

Table 1

Subsample with E2 in P1 and grade descriptors

Group	n	E1 Media (DE)	E2 Media (DE)
Homework A	6	73.7 (4.0)	71.3 (6.0)
Homework B	18	73.9 (5.7)	74.7 (5.9)
Global	24	73.9 (5.2)	73.8 (6.0)

Source: Own Elaboration

Reliability and agreement among assessors (P1, n = 24)

The rating showed high consistency, with values of: $\alpha = .915$; CCI = .915, 95% CI [.804, .963]; $F(23, 23) = 11.81$, $p < .001$. The mean difference (E2–E1) was -0.01 points, 95% CI $[-1.31, 1.33]$, $t(23) = -0.02$, $p = .986$ (no systematic bias presented).

Box 4

Table 2

Reliability and paired comparison E1–E2

Metrics	Value
Cronbach's alpha	0.915
CCI (two-way, mixed, consistency)	.915 (IC 95 % [.804, .963]); $F(23, 23) = 11.81$; $p < .001$
Difference E2–E1	-0.01 (IC 95 % $[-1.31, 1.33]$); $t(23) = -0.02$; $p = .986$

Source: Own Elaboration

Viewing the agreement

The Bland–Altman test confirmed an absence of bias, with values of: bias = -0.01 ; 95% limits = $[-6.16, 6.14]$; no points outside the limits; $\beta = 0.151$, $p = .222$ (no proportional bias).

Box 5

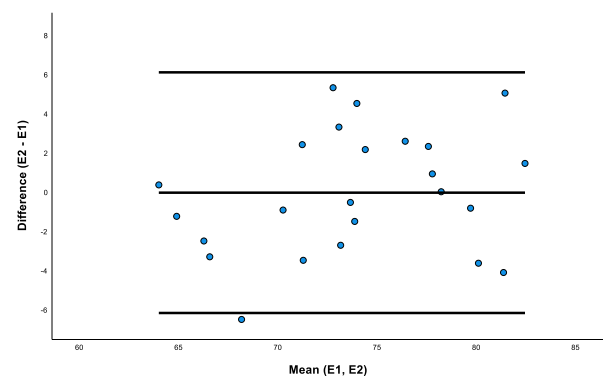

Figure 3

Bland–Altman for E1–E2 (n = 24). Average bias (E2–E1) = -0.01 ; 95% confidence limits = $[-6.16, 6.14]$; no points outside the limits; $\beta = 0.151$, $p = .222$.

Source: Own Elaboration

Performance prediction

In the complete sample (P1+P2, 120 observations), a simple model with pre-tests explained approximately 61% of the variance in E1 (adjusted R^2 close to .611, $F(2,117) = 94.41$, $p < .001$). The CAD pretest was the main predictor ($B = .261$; 95% CI [.214, .308]; $p < .001$) and spatial vision contributed additionally ($B = .180$; 95% CI [.124, .235]; $p < .001$). Similarly, in the E2 subsample, the CAD pretest maintained the pattern; spatial vision was not significant.

Box 6

Table 3

Simple model for E1 (predictors: CAD pretest and spatial vision)

Results	n	Adjusted R^2	F(gl)	p (model)	Predictor	B (IC 95 %)	p
E1	120	0.611	94.41 (2,117)	< .001	Pretest de CAD	.261 [.214, .308]	< .001
					Spatial vision	.180 [.124, .235]	< .001

Source: Own Elaboration

Sequence effect in P2

No difference was detected between AB and BA when adjusting for covariates, with significance values of $p = .384$.

Discussion

Main findings

The present study shows that performance in CAD tasks can be anticipated based on instrumental skills, because: the SolidWorks pretest explained approximately 61% of the variance in E1 (adjusted R^2 close to .611; $F(2,117) = 94.41$, $p < .001$). Likewise, the evaluation process was robust, with high inter-rater reliability ($\alpha = .915$; ICC = .849/.919) and no systematic bias between raters. A task bias (A < B) was identified, which calls for a review of existing anchors in the rubric, where no sequence effect was observed in P2.

Interpretation

The SolidWorks pretest assessment is consolidated as a good predictor of student performance because it captures the sequences of operations, procedures, and commands of the software, aligned with the quality of the product being assessed.

This supports a mechanism for close transfer to better CAD execution. The weak association between pre-tests ($r = 0.16$) and the lower contribution of spatial vision in E2 show that the instruments captured non-equivalent dimensions because spatial vision adds value especially in E1, while the SolidWorks (SW) pre-test offers a direct overview of the procedural domain required for modelling. Overall, the results suggest that specific preparation in the tool (SW) translates into better products, and that instructional support can be focused based on early indicators of workflow (traces) and pre-tests.

Future directions

To strengthen external validity and translate these findings into CAD curriculum improvements, the following lines of work are prioritised with explicit design and evaluation criteria:

- **Replication and sample size.** It is advisable to conduct replicas at multiple sites, calculating the sample size for an E1–E2 equivalence test, defining a target equivalence margin with standardised criteria to be established by the faculty (panel of experts).
- **Balance and design.** Balance A/B and AB/BA with stratification by shift and explicitly model the carry-over effect in the crossover design.
- **Rubric (task A).** Conduct a controlled trial, introducing anchors and examples of borderline performance, as well as evaluating the impact on bias by task and fairness by subgroups.
- **Modelling and prediction.** Employ mixed-effects models that integrate geometric complexity and reconstruction time, with cross-validation and out-of-sample evaluation to generate robust predictive performance.

Conclusion

The study carried out in this work confirmed the validity of the design applied without sequence effects and with high inter-rater reliability. This justifies operating with a single rating, complemented by periodic audits and the application of elements to generate traceability in the study.

The SolidWorks pretest is consolidated as a key predictor of performance and indicates early detections that can be made to generate targeted support where required. Spatial vision, meanwhile, provides additional information, especially for E1, and guides timely educational planning. Furthermore, the identification of task bias ($A < B$) justifies reviewing and balancing the criteria of the A rubric before its next implementation.

Taken together, all these findings allow for the optimisation of assessment and teaching in CAD courses and provide a basis for future evidence-guided applications and curricular adjustments.

Appendices

Box 7

Table 4

Table A2. Paired comparison E1–E2 and effect sizes (subsample P1, $n = 24$)

A) Paired correlation

Par	r	p
E1 with E2	0.852	< .001

B) Paired samples t-test. (difference = E2 – E1)

Δ media	IC 95 % de Δ	$t(23)$	p
-0.01	[-1.31, 1.33]	-0.02	0.986

C) Effect sizes (paired)

Index	Point estimate	IC 95 %
Cohen's d	0.004	[-.397, .404]
Hedges' g	0.004	[-.390, .397]

Source: Own Elaboration

Box 8

Table 5

Table A3: Baseline comparability between included (valid E1–E2 pairs) and excluded (P1, planned E2 subsample) $n=30$

Variable (scale)	Included $n=24$ (Mean)	Excluded $n=6$ (Mean)	Test	p
SolidWorks pretest (0–100)	63.2	62.3	Mann–Whitney	0.67
Spatial vision (0–100)	65.8	65.4	Mann–Whitney	0.6
Overall average, GPA (0–10)	8.3	8.37	Mann–Whitney	0.49
Previous CAD/Ind. 4.0 courses (count)	1.01	1.04	Mann–Whitney	0.62
Proportion per shift (morning/ev evening)	—	—	$\chi^2(1) = 0.00$	1

Source: Own Elaboration

Box 9

Table 6

Table A4: Sensitivity model for E2 (P1): sequence control (AB/BA). $n = 24$ (complete pairs E1–E2 in P1). Dependent variable: E2_rubrica. $R^2 = .408$; adjusted $R^2 = .319$.

Source	gl	F	p	η^2 parcial
Corrected model	3	4.599	0.013	0.408
pretest_SW	1	10.657	0.004	0.348
pretest_vision	1	1.116	0.303	0.053
sequence_num (AB vs BA)	1	1.784	0.197	0.082
Error	20	—	—	—

Source: Own Elaboration

Statements

Conflict of Interest

The authors declare that they have no conflicts of interest.

Contribution of authors

Corral-Verdugo, Alex: Conceptualisation, Methodology, Research, Data curation, Formal analysis, Visualisation, Original draft writing, Project management, Corresponding author.

He led the study design (AB/BA crossover), coordinated trace capture and processing, performed the main statistical analyses (reliability, Bland–Altman, regressions), prepared figures/tables, and wrote the initial manuscript.

Sepúlveda-Romo, Adrián: Methodology, Software, Resources, Research, Validation, Writing–revision and editing. He configured the SolidWorks environment and the virtual classroom, supported the instrumentation for trace extraction, supervised the logistics of the sessions, validated the integrity of the data, and contributed substantive revisions to the text.

Jimenez-Lopez, Eusebio: Resources, Instrumentation, Research, Data Curation, Writing–Revision and Editing. He co-developed and refined the rubrics and short tests, supported classroom implementation and anonymisation protocols, curated the data sets, and reviewed the manuscript for clarity and pedagogical alignment.

León-Rochin, Germán: Formal analysis, validation, visualisation, writing–review and editing. Advised on statistical strategy (CCI models, mixed models, sensitivity analysis), verified reproducibility (SPSS syntax), refined figures and provided critical editorial feedback.

Availability of data and materials

The data and analysis materials (CSV/Excel, SPSS v27 syntax, and replication guide) will be openly available on Zenodo; the DOI will be provided upon publication of the article.

Funding

The research did not receive any funding.

Abbreviations

AB/BA: balanced sequence (A followed by B / B followed by A)

AUC: area under the ROC curve

BA (Bland–Altman): graph of differences and average

CAD: computer-aided design

ICC: intraclass correlation coefficient

SD: standard deviation

E1: rating of the primary assessor

E2: rating of the secondary assessor

EMMs: estimated marginal means

GLM: general linear model

95% CI: 95% confidence interval

K–S / S–W: Kolmogorov–Smirnov / Shapiro–Wilk tests

LoA: limits of agreement (Bland–Altman)

MICE: multiple imputation by chains of equations

OR: odds ratio

P1 / P2: period 1 / period 2

ROC: receiver operating characteristic

Adjusted R²: adjusted coefficient of determination

SPSS: Statistical Package for the Social Sciences

SW: SolidWorks

VIF: variance inflation factor

References

Background

Bartlett, K. A., & Camba, J. D. (2023). Toward a broader understanding of spatial ability in CAD education. *Computer-Aided Design and Applications*, 24(1), 39-54. <https://doi.org/10.14733/cadaps.2024.39-54>

Merzdorf, H. E., Jaison, D., Weaver, M. B., Linsey, J., Hammond, T., & Douglas, K. A. (2024). Sketching assessment in engineering education: A systematic literature review. *Journal of Engineering Education*, 113(4), 872-893. <https://doi.org/10.1002/jee.20560>

Essentials

Anghel, E., Khorramdel, L., & von Davier, M. (2024). The use of process data in large-scale assessments: A literature review. *Large-scale Assessments in Education*, 12(1), 13. <https://doi.org/10.1186/s40536-024-00202-1>

Aranburu, A., Camba, J. D., Justel, D., & Contero, M. (2023). An improved explicit reference modeling methodology for parametric design. *Computer-Aided Design*, 161, 103541. <https://doi.org/10.1016/j.cad.2023.103541>

Bojčetić, N., Žeželj, D., Martinec, T., & Valjak, F. (2021). Automatized evaluation of students' CAD models. *Education Sciences*, 11(4), 145. <https://doi.org/10.3390/educsci11040145>

Company, P., Contero, M., Otey, J., & Plumed, R. (2015). Approach for developing coordinated rubrics to convey quality criteria in MCAD training. *Computer-Aided Design*, 63, 101–117. <https://doi.org/10.1016/j.cad.2014.10.001>

Contero, M., Pérez-López, D., Company, P., & Camba, J. D. (2023). A quantitative analysis of parametric CAD model complexity and its relationship to perceived modeling complexity. *Advanced Engineering Informatics*, 56, 101970. <https://doi.org/10.1016/j.aei.2023.101970>

Jaakma, K., & Kiviluoma, P. (2019). Auto-assessment tools for mechanical computer aided design education. *Heliyon*, 5(10). <https://doi.org/10.1016/j.heliyon.2019.e02622>

Mandorli, F., & Otto, H. E. (2024). Improving the learning experience within MCAD education: The provision of feedback on CAD model quality and dormant deficiency in real-time. *Computer-Aided Design and Applications*, 21(5), 739–758. <https://doi.org/10.14733/cadaps.2024.739-758>

Nobes, D. S. (2025). Automating the assessment of CAD drawings and solid models. *Proceedings of the Design Society*, 5, 691–700. <https://doi.org/10.1017/pds.2025.10083>

Otto, H. E., & Mandorli, F. (2021). Advancing formative assessment in MCAD education: The visual analytics of parametric feature-based solid models. *Advanced Engineering Informatics*, 48, 101308. <https://doi.org/10.1016/j.aei.2021.101308>

Otto, H. E., & Mandorli, F. (2025). Formative feedback improvement in MCAD education: Supporting knowledge-driven dormant deficiency detection and analysis. *Computer-Aided Design and Applications*, 22(4), 652–672. <https://doi.org/10.14733/cadaps.2025.652-672>

Paulsen, L., & Lindsay, E. (2024). Learning analytics dashboards are increasingly becoming about learning and not just analytics: A systematic review. *Education and Information Technologies*, 29, 14279–14308. <https://doi.org/10.1007/s10639-023-12401-4>

Riestra-González, M., del Puerto Paule-Ruíz, M., & Ortín, F. (2021). Early prediction of students' academic performance with learning analytics. *Computers & Education*, 163, 104108. <https://doi.org/10.1016/j.compedu.2020.104108>

Sailer, M., Ninaus, M., Huber, S. E., Bauer, E., & Greiff, S. (2024). The end is the beginning is the end: The closed-loop learning analytics framework. <https://doi.org/10.1016/j.chb.2024.108305>

Simonsmeier, B. A., Flaig, M., Deiglmayr, A., Schalk, L., & Schneider, M. (2022). Domain-specific prior knowledge and learning: A meta-analysis. *Educational psychologist*, 57(1), 31–54. <https://doi.org/10.1080/00461520.2021.193970>

Susnjak, T., Ramaswami, G. S., & Mathrani, A. (2022). Learning analytics dashboard: a tool for providing actionable insights to learners. *International Journal of Educational Technology in Higher Education*, 19(1), 12. <https://doi.org/10.1186/s41239-021-00313-7>

Wang, F.-H. (2021). Interpreting log data through the lens of learning design: Second-order predictors and their relations with learning outcomes in flipped classrooms. *Computers & Education*, 168, 104209. <https://doi.org/10.1016/j.compedu.2021.104209>

Xie, C., Zhang, Z., Nourian, S., Pallant, A., & Bailey, S. (2014). On the instructional sensitivity of CAD logs. *International Journal of Engineering Education*, 30(4), 760–778.

Zhu Zhu, C., Leung, C. O. Y., Lagoudaki, E., Velho, M., Segura-Caballero, N., Jolles, D., ... & Klapwijk, R. (2023, April). Fostering spatial ability development in and for authentic STEM learning. In *Frontiers in Education* (Vol. 8, p. 1138607). Frontiers Media SA. <https://doi.org/10.3389/feduc.2023.1138607>

Zou, Q., Feng, H. Y., & Gao, S. (2023). Variational direct modeling: A framework towards integration of parametric modeling and direct modeling in CAD. *Computer-Aided Design*, 157, 103465. <https://doi.org/10.1016/j.cad.2022.103465>

Background

CONALEP. (2023). Mapa Curricular. Profesional Técnico Bachiller en Mecatrónica. CONALEP. https://www.conalep.edu.mx/sites/default/files/micrositios/MapaCurricular/MC_MECATRÓNICA23.pdf

Dilling, F., & Vogler, A. (2021). Fostering spatial ability through computer-aided design: A case study. *Digital Experiences in Mathematics Education*, 7(2), 323-336. <https://doi.org/10.1007/s40751-021-00084-w>

Gittinger, M., & Wiesche, D. (2024). Systematic review of spatial abilities and virtual reality: The role of interaction. *Journal of Engineering Education*, 113(4), 919-938. <https://doi.org/10.1002/jee.20568>

Secretaría de Educación Pública. (2022). *Mecatrónica*. Coordinación Sectorial de Fortalecimiento Académico. https://cosfac.sems.gob.mx/Docentes/Programas_de_estudio_del_Bachillerato_Tecnologico_Formacion_Profesional/Programas_de_estudio_de_ED_2022/DGETI/Mecatrónica.pdf

Support



Eltaief, A., Ben Amor, S., Louhichi, B., Alrasheedi, N. H., & Seibi, A. (2024). Automated Assessment Tool for 3D Computer-Aided Design Models. *Applied Sciences*, 14(11), 4578. <https://doi.org/10.3390/app14114578>

Environmental impact of wastewater discharges containing surfactants and their effect on biomass in anaerobic reactors during treatment

Impacto ambiental por descargas de aguas residuales con tensoactivos y su efecto en la biomasa de reactores anaerobios durante su tratamiento

Terreros, Jesús^{a*}, Velazquez, Gisela^b and Muriel, Frank^c

^a  Universidad Tecnológica del Valle de Toluca •  0000-0003-4456-699X •  80092

^b  Universidad Tecnológica del Valle de Toluca •  0000-0002-1047-6518 •  413416

^c  Universidad Tecnológica del Valle de Toluca

Classification:

Area: Biotechnology and Agricultural Sciences

Field: Agricultural Sciences

Discipline: Agronomy

Subdiscipline: Use and conservation of water

 <https://doi.org/10.35429/JTD.2025.9.22.4.1.16>

History of the article:

Received: January 13, 2025

Accepted: November 10, 2025

*  [\[jesus.terreros@utvtol.edu.mx\]](mailto:jjesus.terreros@utvtol.edu.mx)



Abstract

The widespread use of surfactants in domestic, industrial, and agricultural products has sparked growing concern due to their environmental persistence and potential for bioaccumulation in living organisms. The results showed that the biomass from the acidogenic reactor was able to eliminate this pollutant in terms of its COD (mg/L) by 42.24% and surfactant biodegradation at a concentration of 200 mg/L by 86.65% (experiment V), with a simultaneous desorption and biodegradation dynamic of 39.38 mg/day. At 300 mg/L (experiment VI), these values decreased to 36.6% and 55%, respectively. The methanogenic reactor fed with the effluent from this reactor showed a COD removal and LAS biodegradation efficiency of 83.17% and 13.85% with a bioaccumulation rate of 30.18 mg/day (experiment III). While at a LAS concentration of 300 ± 0.05 mg/L (experiment VI), the LAS accumulation trend in the biomass of both reactors was 29.41 mg/d and 21.07 mg/d.

Resumen

El uso masivo de surfactantes en productos domésticos, industriales y agrícolas ha provocado una creciente preocupación debido a su persistencia ambiental y su capacidad de bioacumulación en organismos vivos. Los resultados mostraron que la biomasa del reactor acidogénico logró eliminar este contaminante en términos de su DQO (mg/L) en un 42,24 % y de biodegradación del tensoactivo a una concentración de 200mg/L en un 86,65 % (experimento V) y una dinámica de desorción y biodegradación simultánea de 39,38 mg/día. A 300 mg/L (experimento VI), estos valores se reducen al 36,6 % y 55 %, respectivamente. El reactor metanogénico alimentado con el efluente de este reactor, mostró una eficiencia de eliminación de DQO y de biodegradación de LAS del 83,17 % y del 13,85 % con una tasa de bioacumulación de 30,18 mg/día (experimento III). Mientras que a una concentración de LAS de $300 \pm 0,05$ mg/L (experimento VI), la tendencia de acumulación de LAS en la biomasa de ambos reactores, fue de 29,41 mg/d y 21,07 mg/d.

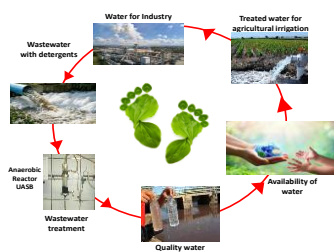

Environmental impact, bioaccumulation, ecosystems, biodiversity, anaerobic reactor, surfactants

Impacto ambiental, bioacumulación, ecosistemas, biodiversidad, reactor anaerobio, tensoactivos

Area: Development of strategic leading-edge technologies and open innovation for social transformation

Citation: Terreros, Jesús, Velazquez, Gisela and Muriel, Frank. [2025]. Environmental impact of wastewater discharges containing surfactants and their effect on biomass in anaerobic reactors during treatment. Journal of Technological Development. 9 [22] 1-16: e40922116



ISSN 2531-2960/© 2009 The Authors. Published by ECORFAN-México, S.C. for its Holding Spain on behalf of Journal of Technological Development. This is an open-access article under the license CC BY-NC-ND license [<http://creativecommons.org/licenses/by-nc-nd/4.0/>]

Peer review under the responsibility of the Scientific Committee MARVID® in the contribution to the scientific, technological and innovation Peer Review Process through the training of Human Resources for the continuity in the Critical Analysis of International Research.



Introduction

Surfactants are adjuvant chemical compounds, many of which are used to enhance the effectiveness of biologically active substances such as herbicides or pesticides. Most act at fluid interfaces and have a bipolar structure with hydrophilic and hydrophobic portions that allow them to interact with cell surfaces and biological membranes in general, affecting surface tension and the mobilization of molecules between extracellular and intracellular media. This can cause direct injury to the epithelial membranes of vital organs of aquatic animals, such as the gills; when released into the environment through domestic and industrial wastewater, runoff and leaching from agricultural fields, and by wind action in aerial spraying of agrochemicals (Vázquez, 2024).

According to their structure, they are called surfactants; they have foaming, emulsification, detergency, and particle suspension properties. These types of substances are called emerging contaminants (Gomes *et al.*, 2018). Worldwide, it is estimated that surfactant production increased from 9.25 million tons in 1995 to 11 million tons in 2000, with an average annual growth of 3.5%. Asia is the largest producer of these products, accounting for 45% of the total, followed, in order, by Europe with 28% and the Americas with 22%. It is estimated that national production of surfactants for the year 2002 was approximately 24,053 tons, of which 2,747 were exported, with a total import of 8,126 tons (CENIPALMA, 2005).

Two decades ago, over 4.2 million tonnes (MT) of detergents and 1.2 MT of fabric softeners were used annually in Western Europe (Ivanković & Hrenović, 2010). Global annual surfactant production stood at 7 MT in 2000 (Pettersson *et al.*, 2000), which increased significantly to 12.5 MT in 2006 and 14.1 MT in 2017, with an estimated growth of 18% by 2022 (Johnson *et al.*, 2021). Global demand for surfactants has increased by 300%, surpassing the current global production of 3 million tons per year and consumption of 18 million tons. In Mexico, Procter & Gamble has a production capacity of 180,000 tons per year of powder and liquid detergents; exporting 45% of what is produced in the country (Procter & Gamble Mexico, 2025).

Linear alkylbenzene sulfonate (LAS) [$C_{12}H_{25}C_6H_4SO_3^-Na^+$] are the most commonly used in the production of personal detergents (laundry and cleaning products), and frequently use sodium salts as the sole surfactant in a formulation or together with other anionic, non-ionic or cationic surfactants.

This compound is characterized by an alkyl chain of 11 carbon atoms (C₁₁-LAS) to which a sulfonated aromatic ring is attached in the "para" position. Linear alkylbenzenes are obtained from n-paraffins (C₁₀ to C₁₄) either by partial dehydrogenation to obtain olefins, and the subsequent addition of benzene (C₆H₆) using hydrogen fluoride (HF) as a catalyst; or by chlorination of the paraffins followed by the Friedel-Crafts reaction, using benzene and an aluminum chloride catalyst (Maloney, 2008).

Within the production of detergents, LAS are the most important in the world and are one of the most widely used sulfonated hydrocarbons with an annual production of approximately 1X10⁶ ton/year in the United States out of a worldwide detergent production of 15X10⁶ ton/year (Mogensen *et al.*, 2003). Linear alkylbenzene (LAS) as an anionic surfactant, presented a consumption of 270,000 tonnes/year in Europe in 2000 (European Eco-Label, 2002).

Currently, linear alkylbenzene sulfonate (LAS) is one of the most widely used sulfonated hydrocarbons with an annual production of approximately 1X10⁶ ton/year in the United States out of a worldwide detergent production of 15X10⁶ ton/year (Mogensen *et al.*, 2003).

With an estimated market size of linear alkylbenzene at USD 28.49 Billion in 2023. And the linear alkylbenzene market industry is expected to grow from USD 29.14 Billion in 2024 to USD 35.0 Billion by 2032. With a market growth rate of linear alkylbenzene in the order of 2.31% during the period from 2025 to 2032 (Research Report, 2024) and an increasing demand in Europe, United States, Japan, and developing countries, to reach a global consumption volume in the order of 18 million tons by 2050 (Zhu *et al.*, 2018).

In recent years, an increase in the consumption of anionic surfactants of the sodium alkylbenzene sulfonate (LAS) type has been observed, since they are the most widely used in the synthesis of anionic surfactants, which are used as active agents in various cleaners such as detergents, shampoos, toothpastes, etc., with a per capita consumption in Eastern Europe, USA and Japan, in the order of 3 to 5 g of LAS per inhabitant per day, and consumption in Southern Africa and East Asia, at 1 g per inhabitant per day (Berna *et al.*, 1991).

In Mexico, a production of 528,481 tons/year is reported, internationally, it occupies the 5th place among detergent producers (4.4%), United States (16.5%), Brazil (6.4%), China (5.0%) and Germany (4.7%). This means that per capita consumption in Mexico is high, at 10 kilos per year, a figure higher than that of other countries given the population growth rate, according to INEGI, (National Institute of Statistics, Geography and Informatics, 2013).

In addition to surfactants, detergents contain phosphates (such as sodium tripolyphosphate), optical brighteners, fragrances, and preservatives. The bioaccumulation of surfactants alters the synthesis and stability of photosynthetic pigments, affecting photosynthesis in exposed plants. They can damage cellular proteins or alter their production. Genisel & Eren (2020) found that sodium dodecyl sulfate (SDS) not only reduced pigments but also decreased soluble protein content in barley leaves.

The presence of sulfate, another component of SDS, at high concentrations in cells disrupts the intracellular colloidal structure. In such a case, excess sulfate in plant tissues retards plant growth by disrupting synthesis reactions and cell division. In this study, protein content results have already shown that SDS significantly affects biosynthesis reactions. Irrigation with gray laundry water used in irrigation has negative impacts on soil properties, for example; reduces bean growth and alters the chlorophyll and crude protein content of plants, detergents tend to degrade or alter essential proteins, affecting metabolic processes linked to protein synthesis (Abu-Zreig *et al.*, 2003) mainly associated with the dispersion of aggregates due to the accumulation of sodium (Misra & Sivongxay, 2009).

And the modification of hydrodynamic properties of soils caused by the accumulation of surfactants (Lado & Ben-Hur, 2009). Exposure to high concentrations of detergents in irrigation water triggers oxidative stress responses in corn seedlings, in addition to a decrease in the activities of antioxidant enzymes such as superoxide dismutase, catalase, ascorbate peroxidase, and glutathione reductase in SDS-treated barley, accompanied by a strong increase in free radicals and lipid peroxidation (Genisel & Eren, 2020).

Their bioaccumulation can cause serious alterations in plant metabolism: a) Reduction in plant growth; i.e., stem shortening, decreased leaf mass, and b) Interference with nutrient uptake: Due to competitive blockage or root damage. c) Oxidative stress: Production of reactive oxygen species (ROS) that damage lipids and proteins. "The presence of pollutants generates oxidative stress, damaging cell membranes and reducing photosynthetic efficiency" d) Photosynthetic alterations: Loss of chlorophyll, inefficiency in the electron transport chain (Hernández-Baranda, 2023).

Exposure of coastal vegetation to surfactants results in an indirect absorption of sodium chloride and a reduction in water surface tension, caused by the erosion of the epicuticular wax of plants. In hyacinth, it affects the inherent salinity tolerance of water, which is reduced by exposure to the surfactant. In soil, LAS impedes microbial processes, such as bacterial iron reduction. Its continuous application increases the concentration of acid and alkaline phosphatase, also causing a decrease in the activity of arylsulfatase and dehydrogenase. High concentrations of LAS exert selective pressure on the diversity of heterotrophic bacteria; while even at low concentrations, surfactants significantly affect soil physics, chemistry, and biology (Badot *et al.*, 1993).

LAS toxicity data (lethal concentrations, EC₅₀) for aquatic organisms range from 1 to 10 mg per liter in short-term tests. LAS is approximately equally toxic to fish and invertebrates, while its toxicity to algae varies widely (Hashim & Kulandia, 1992). At doses of 30 ppm, it induces inhibition of coastal organisms (Bressan *et al.*, 1991).

Exposure of coastal vegetation to surfactants results in an indirect absorption of sodium chloride and a reduction in water surface tension caused by erosion of the epicuticular wax of plants. In hyacinth, it affects the inherent tolerance to water salinity, which is reduced by exposure to the surfactant. Exposed vegetation may receive up to 0.1 mg of anionic detergents, 1.5 mg of petroleum products, and 20 mg of NaCl per square meter of leaf area daily (Badot *et al.*, 1993). Therefore, detergent concentrations in water of 2.5 mg/L affect plant growth and concentrations of 5 to 6 mg/L are toxic to algae and fish in general (Marin, 1995).

This causes water to tend to leave the plant cells, affecting turgor; 1) biochemical alterations, 2) decreased photosynthesis. Damage to chloroplasts reduces the synthesis of chlorophyll a and b, which lowers the efficiency of light capture, that is: Less chlorophyll → less sugar production → less energy for growth (Hernández-Baranda *et al.*, 2023). Damage to membranes and organelles increases the production of free radicals such as $O_2^{\bullet-}$ and H_2O_2 . These radicals oxidize lipids, proteins and DNA, accelerating cell aging and causing leaf necrosis (Sharma *et al.*, 2012). Anaerobic microorganisms appear to be the most affected by the presence of surfactant (Van Hamme *et al.*, 2006).

The toxicity of surfactants in the environment is affected by various physical, chemical and biological factors that interact with each other, such as temperature and pH. Buhl & Hamilton (2000) suggest that the toxicity of the anionic surfactant sodium dodecyl sulfate (SDS) increases with increasing temperature.

In domestic wastewater average concentrations of LAS have been found from 1 to 20 mg/L in surface waters at 0.5 mg/L and in wastewater from detergent producing industries, average concentrations of 300 mg/L (Fox *et al.*, 2000). Its gross discharge into rivers increases the level of surfactants and other contaminants representing a threat to the resident macro and micro populations (Cirelli & Ojeda, 2008). The toxic effects of surfactants in aquatic organisms are mainly due to their ability to adsorb and penetrate the cell membrane of aquatic organisms (Rebello *et al.*, 2013).

They generate deleterious effects in aquatic organisms by binding to epithelial membranes of their respiratory structures, such as the external gills of amphibians, specialized cell areas of invertebrates, and teleost gills. At the gill level, they can cause histological and ultrastructural lesions, including detachment, necrosis, hyperplasia, hypertrophy, and rupture of the gill epithelium.

These lesions are found in fish exposed to media contaminated with other toxins such as heavy metals, pesticides, organotins, organic solvents, and organic xenobiotics. Depending on their concentration, they are toxic to aquatic organisms because they hinder the transfer of oxygen in the water. High concentrations of surfactants cause death of fish due to; decreased surface tension, tissue destruction and alteration of biomacromolecules (Rosety-Rodríguez *et al.*, 2002). Aquatic plant species are also affected by the toxic effects of surfactants. These break the chlorophyll-protein complex, damaging the cell membrane, which delays metabolism and growth rate (Jardak *et al.*, 2016). In *Azolla pinnata* and *Hydrilla verticillata*, exposed to different concentrations for four weeks, a significant reduction in chlorophyll was observed in the leaves of *A. pinnata* at concentrations above 2 ppm of sodium lauryl sulfate (SLS). Meanwhile, *H. verticillata* turned completely brown at 10, 15, and 20 ppm of SLS. When exposed to sodium dodecylbenzenesulfonate (SDBS), chlorophyll content in both plants decreased at all concentrations (Mousavi & Khodadoost, 2019).

In *macrophytes* such as *Elodea canadensis* and *Myriophyllum spicatum*, photosynthesis was reported to be reduced by 50% after exposure to 1.0 mg/L of LAS (Lewis, 1990). They can also generate adverse effects on terrestrial plants, due to their ability to alter their membranes (Cuevas *et al.*, 2023). Several studies have shown phytotoxic effects derived from exposure to detergents. Hernández-Baranda (2023) reports that, under controlled conditions, increased detergent concentration significantly decreases germination and seedling development, evidenced by shorter stem and root lengths. These effects are visible symptoms such as chlorosis, wilting, necrosis, and reduction in leaf size.

The magnitude of this damage depends on factors such as its concentration, type of detergent, exposure time, and the plant species involved. (Vázquez, 2024). The accumulation of surfactants leads to the production of ammonia, which can affect the synthesis of substances essential for the metabolism of fish, crustaceans, and bacteria, in addition to affecting the growth of phytoplankton (Cardenas & Sanchez, 2013). Their bioaccumulation in aquatic organisms occurs through different mechanisms, largely due to their amphipathic structure, which allows them to interact with cell membranes and fatty tissues.

Therefore, the presence of surfactants in aquatic ecosystems not only represents a threat to biodiversity, but also constitutes a food safety and public health issue that demands urgent monitoring, control, treatment, and mitigation strategies. Over the past 50 years, biodiversity loss has been accelerated by external factors, including global warming, climate change due to anthropogenic activities, and industrial wastewater discharges containing high concentrations of highly toxic pollutants, such as surfactants made from linear alkylbenzene sulfonate (LAS) (Figure 1). Furthermore, the presence of volatile, emerging, and persistent organic compounds represents a new global challenge to water quality in developed and developing countries, posing potentially serious threats to human health, the environment, and ecosystems (WHO/UNICEF, 2015).

Their impacts on aquatic and terrestrial ecosystems can be summarized in three broad categories: a) Eutrophication and loss of water quality (Pérez-García, 2023), b) Alteration of the soil microbiota and c) Phytotoxicity in plants. Plants exposed to detergents show symptoms of chemical stress, such as chlorosis, necrosis, delayed germination, and reduced growth (Cuevas *et al.*, 2023). Hernández-Baranda (2023) documented that exposure of seedlings to household detergents caused a significant decrease in root and stem length, accompanied by visible changes in leaf color. The impact of surfactants on aquatic and terrestrial life depends on their chemical nature (Jardak *et al.*, 2016). In soil, they can modify soil pH, electrical conductivity, and nutrient availability: salinity and pH increase in soils treated with detergents, affecting nitrogen and potassium availability (Sharma *et al.*, 2012).

The phosphates present in some detergents contribute to eutrophication, affecting aquatic plants and surrounding areas. They reduce the surface tension at the air-water interface, which in turn causes a proportional decrease in capillary pressure. In recent years, the problem of contamination of water bodies has been a cause of great concern, due to the toxicity caused by xenobiotic compounds, such as detergents (Mousavi & Khodadoost, 2019). Worldwide, 80% of domestic wastewater that is discharged does not receive prior treatment before being discharged into a natural body of water World Bank Group (2020). Causing an imbalance in ecosystems, modifying the physicochemical parameters of the water resource and the natural characteristics of the fish fauna that receive these contributions. In a monitoring of 7 wastewater treatment plants, concentrations of AS (C₁₂-C₁₅) were found in their effluents between 0.0012 and 0.012 mg/l, with an average value of 0.0057 mg/L, in the water quality assessment of the Asa River in Ilorin, Kwara State, Nigeria, contamination with industrial detergents was reported (Adekola & Eletta, 2007).

And the waters of the Caspian Sea and the Volga, Terek and Sulak rivers presented a high level of contamination with high concentrations of detergents (Korshenko & Gul, 2005). As well as the coastal areas of the Sea of Okhotsk and the Avacha Bay, on the northwest coast of Russia (Zhuravel *et al.*, 2004). Meanwhile, findings in the waters of the South China Sea showed a concentration of anionic surfactants of 57% in the surface microlayer, and 43% in groundwater (Uning *et al.*, 2022).

Various technologies have been employed for the treatment of wastewater containing high concentrations of anionic, cationic, non-ionic and ampholytic/zwitter ionic surfactants, including; adsorption processes, chemical oxidation, ozonation, hydrogen peroxide, ultraviolet light irradiation, iron salts (Ikehata and El-Din, 2004), advanced oxidation processes, photocatalytic degradation (Bandala *et al.*, 2008), sonochemical processes (Dehghani *et al.*, 2010), ultrasound (Naldoni *et al.*, 2011) electrocoagulation, nanofiltration, aerobic or anaerobic biological processes and electrochemical processes (Korzenowski *et al.*, 2012).

Based on previous studies, the objective of this research was to evaluate the toxic effect and accumulation rate of the surfactant "LAS" in the biomass of UASB-type anaerobic reactors during the treatment of wastewater with high concentrations of detergents.

2. Materials and methods

2.1. Start-up and operation of the reactors

During the start-up of the anaerobic reactors, the first reactor was fed with lactose as the sole carbon source at a concentration of 1 g/L to promote acidogenic conditions and RAAM mineral medium (Shelton & Tiedje, 1984) (Experiment I) and the second reactor was fed with the effluent from this reactor. The synthetic wastewater was prepared with 1 g/L of lactose and surfactant "LAS" at a concentration of 200 mg/L, increasing to 300 mg/L during experiment VI.

2.2 Sample characterization

For the characterization of the synthetic water and process control, the main parameters were evaluated: Chemical oxygen demand (COD) and linear alkylbenzene sulfonate (LAS), according to standard methods (APHA, 2012) and the pH using a potentiometer (Corning pH/ion Analyzer 455).

2.3. Inoculum

The biomass used as inoculum for the UASB acidogenic and methanogenic reactor was collected from a UASB reactor that treats wastewater at the Universidad Autónoma Metropolitana Iztapalapa Unit, Mexico City. It presented a concentration of 63.9 g/L TSS, 37.5 g/L VSS, and a specific methanogenic activity (SMA) of 0.15 L CH₄/g VSS d.

2.4. Operating conditions of UASB type acidogenic-methanogenic reactors

The design volume of the first reactor was 0.5 L, with a useful volume of 0.360 L, operated at a hydraulic retention time (HRT) of 0.25 days, fed with RAMM mineral medium (Shelton & Tiedje, 1984)

And lactose as the sole carbon source to promote the development of acidogenesis conditions and the conversion of volatile fatty acids (VFA) during acetogenesis, forming acetate, hydrogen and carbon dioxide and with the acetate produced, promote methanogenic conditions in the second reactor.

The design volume of the second reactor was 1.5 L, useful volume 1.44 L operated at a HRT of 1 day, operating both reactors at an average temperature of the order of 30±0.5°C.

Box 1

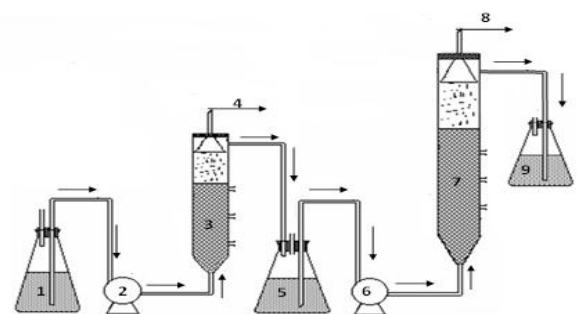

Figure 1

Process description: 1) Surfactant wastewater, 2) Peristaltic pump, 3) UASB acidogenic reactor, 4) Biogás pipeline, 5) Treated wastewater by acidogenic reactor, 6) Peristaltic pump, 7) UASB methanogenic reactor, 8) Biogás pipeline, 9) Treated wastewater by methanogenic reactor.

2.5 Reactor monitoring

To evaluate the efficiency and performance of the studied system for the simultaneous biodegradation of LAS, 100 mL spot samples of the effluent from each reactor were taken every two days, and the main parameters were analyzed: COD, LAS, pH, and CH₄ produced in the methanogenic reactor. Based on the parameter differences between the influent and effluent, the COD removal rate, LAS biodegradation, and biogas production were estimated.

3. Analysis and discussion of results

3.1 Characterization of synthetic wastewater

Before addressing the analysis of the results, Table 1 presents the averages of the main parameters evaluated in the synthetic water with surfactant (LAS).

Box 2**Table 1**

General characteristics of the synthetic wastewater fed to the studied system

Parameter	Experiment						
	I	II	III	IV	V	VI	VII
Time of operation (days)	0-62	63-120	121-174	175-244	245-290	291-343	344-374
pH	7.05±0.1	7.1±0.11	6.94±0.2	7.02±0.09	7.08±0.12	6.94±0.13	7.08±0.1
COD (mg/L)	1118.6±14.1	1499±18.9	1479±20.4	1123±15.1	1503±22.7	1709±24.5	1074±13.9
BOD ₅ (mg/L)	655.6±8.1	878±10.4	866.8±10.1	658.2±8.8	880.9±12.1	1001±14.4	629.4±8.1
LAS (mg/L)	0	200±0.08	200±1.3	0	200±0.09	300±0.05	0

3.2 Reactor start-up and operation

Once the system of anaerobic reactors operated in series, the object of this study was launched, the acidogenic reactor was initially fed with lactose (Experiment 1), to achieve the conditions of acidogenesis in the acidogenic reactor and with the conversion of acids volatile fatty acids (VFA) in acetate as the main substrate of the biomass of the methanogenic reactor and start from experiment II, with the feeding of the surfactant and monitor the performance of both reactors on their COD removal capacity and biodegradation of the LAS.

3.3 Characterization of the water treated

Tables 2 and 3 show the physicochemical characteristics of the water treated by both reactors.

Box 3**Table 2**

Characterization of the water treated by the acidogenic reactor

Parameter	Experiment						
	I	II	III	IV	V	VI	VII
pH	4.4±0.11	4.8±0.08	4.4±0.11	4.5±0.12	4.6±0.13	4.4±0.1	4.4±0.12
COD (mg/L)	789±10.8	726.8±9.7	1035±14.2	739±10.4	868±11.3	1083±14.9	717.4±8.9
BOD ₅ (mg/L)	462.4±6.2	425±5.4	606.6±7.3	433.1±5.8	508.7±6.4	634.7±7.9	420.4±5.2
LAS (mg/L)	N.A	38.8±0.7	88±0.8	12.48±0.9	26.7±1.1	135±0.9	28.05±1.1

Box 4**Table 3**

General characteristics of treated water and methane produced by the methanogenic reactor

Parameter	Experiment						
	I	II	III	IV	V	VI	VII
pH	5.6±0.23	6.98±0.12	7.25±0.08	6.8±0.13	7.35±0.1	7.1±0.11	6.6±0.18
COD (mg/L)	372±4.9	171±2.54	372±5.3	130±1.9	146±1.84	590±6.7	449±5.73
LAS (mg/L)	N.A	N.A	59±0.8	4.1±0.5	23±0.7	115±1.1	23±0.9
LCH ₄ /d	0.012±0.03	0.26±0.01	0.19±0.01	0.16±0.01	0.23±0.01	0.10±0.02	0.07±0.03

3.4 COD removal efficiency and LAS biodegradation in the acidogenic reactor

The presence of toxic compounds also influences the reactor's performance on its biodegradation by inhibiting the activity of the bacterial consortium, if an appropriate biomass acclimatization strategy is not used, in which the use of co-substrates is often not necessary (Terreros *et al.*, 2022).

In a study carried out to degrade three anionic surfactants: linear alkylbenzenesulfonate, sodium dodecylsulfonate and sodium dodecyl sulfate by anaerobic digestion, the inhibitory effect of the surfactant on the methanogenesis process was reported at concentrations higher than 100 mg/L in the sludge of an anoxic reactor, and inhibition at concentrations higher than 50 mg/L in the sludge of an anoxic lagoon.

Other studies have reported that during the anaerobic biodegradation of surfactants made with LAS, the most affected bacteria are the acetoclastic methanogenic bacteria during methane production, associated with the high accumulation of acetate, given the inhibitory effect of LAS (Wagener & Schink, 1988). Therefore, the use of bacterial consortia improves the biodegradation of this type of compounds than a single strain, since they are not capable of mineralizing it.

It is evidenced that the key step to carry it out is in the breaking of the benzene ring, and that its complete mineralization improves when coexisting syntrophy, for example: that which occurs between coastal bacteria and strict aerobic bacteria (Sigoiillot & Nguyen, 1992).

The results of COD removal and LAS degradation in the reactor system used in the present investigation are shown below. Figure 4 shows the behavior of the acidogenic reactor (experiments II-VII) on the biodegradation of the surfactant and COD removal at different LAS concentration rates and organic loads.

During the first 60 days of operation (experiment I), both reactors were operated in series, using as a feeding medium a solution made with lactose as a co-substrate at a concentration of 1000 ± 1.1 mg/L and organic load rate of 4.48 ± 0.11 kgCOD/m³d, to achieve acidogenesis conditions in the first reactor from the hydrolysis and fermentation of lactose into simple organic compounds; as short-chain volatile fatty acids (VFA) and intermediate compounds, which are converted into acetate, H₂ and CO₂ by the acetogenic bacteria, acetic acid predominating in relation to the other acids produced (propionic acid and butyric acid), acetate being the main substrate of methanogenic bacteria and at the same time, contribute to the biodegradation of the surfactant in subsequent stages of the experiment.

The literature mentions the use of co-substrates, enriched carbon sources, sodium acetate, yeast extract, the addition of MgSO₄, CaCl₂, sources of phosphorus, and/or the addition of micronutrients among others, to acclimatize the biomass of anaerobic reactors in the biodegradation of recalcitrant compounds present in Industrial wastewater (Wosman *et al.*, 2016). From day 64 to day 174 (experiments II-III), the LAS surfactant is again included at an average concentration of 200 ± 0.69 mg/L which represented an average value of the chemical oxygen demand (COD), biological oxygen demand (BOD₅) and organic load of 1489 ± 19.65 mg/L, 872.4 ± 10.25 mg/L and 5.92 ± 0.7 kgDQO/m³d respectively.

Observing a gradual loss in COD removal efficiency going from 51.51% (experiment II) to 30% during the next 45 days after experiment III began until it became null on day 174 of operation, in addition, a decrease in the biodegradation efficiency of the surfactant of an 80.6% (experiment II) in a 56% (experiment III).

Based on this behavior and to avoid the inhibition of the biomass of the reactor, from day 174 until day 244 (experiment IV) it was decided to suspend the LAS from the feeding medium, which allowed it to improve its performance, achieving COD removal efficiency in a 34.19% and of a 60% of biodegradation of the surfactant present in the biomass of the reactor, appreciating an average concentration of 12.48 ± 0.9 mg/L in the reactor effluent.

This led to the assumption that the surfactant was probably absorbed into the biomass of the reactor. In the literature, it is mentioned that given its chemical nature it can be highly absorbed by the granules and sometimes can represent up to 60% of the total amount (González-Mazo *et al.*, 1998). On the other hand, the primary biodegradation of the different LAS homologs (normally between C₁₀ and C₁₃, but even between C₆ a C₁₆), increases as the length of the alkyl chain increases (Swisher, 1981).

From day 244 to day 290 of operation (experiment V), Again, the surfactant is included in the feed medium at the same surfactant concentration, COD, BOD₅, and organic loading rate similar to the experiments II-III, and a slight improvement is observed in the degradation of COD in a 42.24% and an 86.65% of LAS respectively. This suggested that, once the biomass was acclimated to the presence of LAS in the presence of lactose as a co-substrate, the performance of the reactor improved. Based on these results, it is decided to increase at will, the concentration of LAS to a concentration of 300 ± 0.05 mg/L from day 291 to day 343 of operation (experiment VI), which represents a concentration of 1709 ± 24.5 mg/L of COD, 1001 ± 14.35 mg/L of BOD₅ and organic load rate of 6.8 ± 0.11 kgCOD/m³d.

With the change in feeding conditions, a slight reduction in the COD removal efficiency and LAS biodegradation was observed in a 36.6% and of a 55% respectively, as well as a concentration of LAS in the effluent of the reactor of 67.42 ± 0.9 mg/L. In the literature, it is mentioned that by increasing the concentration of surfactant, a significant increase in the adaptation period and a decrease in the degradation rate is observed. This fact can be attributed to a bacteria-surfactant interaction effect or a decrease in the solubility of dissolved oxygen in the medium.

There are many examples in the literature in which various compounds are shown in initial concentrations between 20-100 mg/L present inhibitory effects on their degradation process, degrading at lower concentrations (Swisher, 1986).

Therefore, it was decided to definitively suspend the LAS of the reactor feeding medium from day 344 of operation (experiment VII), and as time passed, the presence of LAS was observed in an average of 28.05 ± 1.1 mg/L in the reactor effluent, with a COD removal in a 33.2%, which confirmed, the accumulation of LAS in the biomass of the reactor.

Box 5

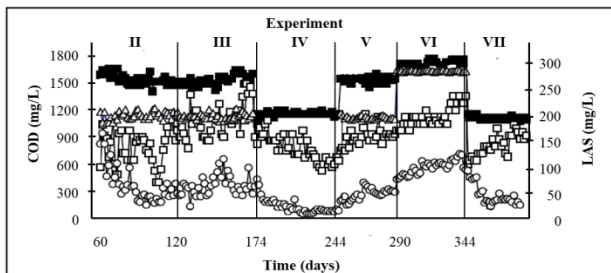

Figure 2

Efficiency of COD removal and surfactant biodegradation in the acidogenic reactor (■ COD and △ LAS in influent, □ COD and ○ LAS in effluent)

3.5 COD degradation and LAS removal efficiency in the methanogenic reactor

Figure 3 shows the behavior of the methanogenic reactor on the efficiency of COD removal and LAS biodegradation once it is coupled to the effluent of the acidogenic reactor. Taking as a basis the basic principle of anaerobic degradation, which consists of the biochemical transformation of organic matter through different groups of microorganisms, whose efficiency depends directly on the substrate and the possible contaminating agents present in wastewater (Lorenzo Acosta, 2005), as well as the interactions between bacterial consortia and consequently, that the activity of methanogenic microorganisms can be affected by the products generated during fermentation, and even the hydrolysis of organic matter, when using lactose as a co-substrate in the acidogenic reactor. Therefore, the fermentation products are converted into acetate, hydrogen and carbon dioxide (Costello 1991) by obligate hydrogen-producing acetogenic bacteria (OHPA for its acronym in English) (Thiele *et al.*, 1988); the acetate produced contributes significantly to the development of the methanogenic conditions of the second reactor to keep the bacterial consortium active during the biodegradation of the surfactant remaining in the effluent of the acidogenic reactor for its mineralization into methane (McCarty, 1964).

Under this context, due to the acidification of the first reactor (experiment I) due to lactose being an easily hydrolyzable substrate, the effluent of the acidogenic reactor, which in turn was the feeding medium of the methanogenic reactor, had a pH of the order of 4.4 ± 0.11 and due to the overload of volatile fatty acids produced, due to the high concentration of VFA and bicarbonate in the medium, the development of the methanogenic pathway could have been affected, which is why it was decided to separate the methanogenic reactor from the acidogenic reactor from the day 63 and until the day 120 of operation (experiment II), feeding it only with acetate as the only carbon source at a concentration of 1000 ± 0.12 mg/L.

Upon observing an improvement in COD removal by 83.95% during this experimental period, it was decided to couple the methanogenic reactor to the effluent from the acidogenic reactor collected in a container where the pH was adjusted to 7.01 ± 0.09 with NaHCO_3 to avoid any disturbance in the performance of the methanogenic reactor during experimental development, in the removal of COD and biodegradation of the surfactant due to the acidic pH of the effluent of the acidogenic reactor.

Under this context, from day 121 to day 174 of operation (experiment III), the feeding medium presented a COD concentration of 1035 ± 14.2 mg/L, BOD_5 of 606.6 ± 7.3 mg/L and organic load of 4.36 ± 0.12 KgCOD/m³.d, that due to the presence of the remaining LAS in the effluent of the acidogenic reactor on average 88 ± 0.8 mg/L, the COD removal efficiency decreased significantly in a 64.05% and of a 32.95% of LAS biodegradation.

However, by suspending the LAS from the acidogenic reactor feed medium from day 175 to day 244 of operation (experiment IV), given the average concentration of surfactant present in the effluent of the first reactor 12.48 ± 0.9 mg/L, an improvement is seen in the efficiency of COD removal and LAS biodegradation in an 82.4% and of a 67.14% respectively. By including the LAS again at a concentration of 200 ± 0.09 mg/L and 1000 ± 0.6 mg/L of lactose in the feeding medium of the acidogenic reactor, from day 245 to day 290 of operation (experiment V); The feeding medium of the methanogenic reactor has the following characteristics:

COD of 868 ± 11.3 mg/L and BOD_5 on the order of 508.7 ± 6.4 mg/L, a LAS concentration of the order of 26.7 ± 1.1 mg/L and organic load rate of 3.56 ± 0.14 kgCOD/m³·d. During this experimental period, a COD removal efficiency similar to the previous stage was observed, and 13.85% LAS biodegradation. This behavior suggested that the biomass of the methanogenic reactor was more sensitive to LAS than the biomass of the acidogenic reactor, which caused it to not biodegrade and, consequently, to bioaccumulate. Once the concentration of LAS in the feed of the acidogenic reactor was increased to 300 mg/L from day 291 to 343 of operation (experiment VI), The COD present in the effluent of the methanogenic reactor, presented a COD value of 1083 ± 14.9 mg/L, BOD_5 of 634.7 ± 7.9 mg/L, an average LAS concentration of 135 ± 0.9 mg/L and organic load rate of 4.48 ± 0.11 kgCOD/m³·d. Appreciating a gradual decrease in both the COD removal efficiency of a 45.52% to 0%, as in the biodegradation of LAS from a 14.81% to 0%.

Box 6

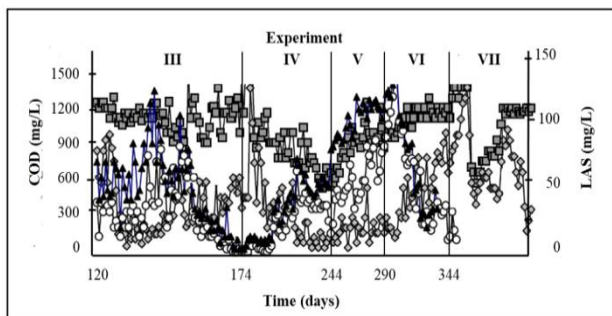

Figure 3

Efficiency of COD removal and surfactant biodegradation in the methanogenic reactor (■ COD and ▲ LAS in influent, ◆ COD and ○ LAS in effluent)

3.6 Bioaccumulation of the surfactant "LAS" in the biomass of the acidogenic reactor and the methanogenic reactor

Figures 4 and 5 show the dynamics of the accumulation of the surfactant "LAS" in the biomass of both reactors. In the literature, it is reported that LAS persist in anaerobic environments such as aquatic sediments and digester sludge, in addition, they do not degrade under anaerobic conditions (Federle & Schwab, 1992). Under anaerobic conditions (Maurer, 1965) showed that there is no degradation of LAS, but there is an inhibition of methanogenesis from a concentration of 214 mg/L.

In another study (Federle & Schwab (1992) confirmed these results by comparing the mineralization of radiolabeled LAS in anaerobic sediments from a lagoon receiving wastewater from laundries and sediments from uncontaminated lagoons as a control. LAS did not mineralize in the anaerobic sediments even though the microorganisms had been exposed to the surfactant for more than 25 years.

Based on the results obtained in this study and the studies cited above, it is evident that the system studied under the operating conditions tested in each of the reactors operated in series, confirms the accumulation of the surfactant in the biomass (Wolf & Feijtel, 1998).

These results confirm two relevant things; 1) the sensitivity of methanogenic bacteria to this type of compound and 2) due to the absorption of LAS in both the biomass of the acidogenic and methanogenic reactors, a bioaccumulation of LAS occurred in both bacterial consortia, as reported by the literature, which can be caused by both biotic and abiotic factors.

Under this context, it is suggested to acclimatize the biomass of the anaerobic reactors to the presence of this type of compound, at low concentrations of surfactant and gradually increase it until the anaerobic biomass of the biological reactors is acclimated or, failing that, to use hydraulic retention times (HRT) higher than that tested in this study. And it can be seen that the LAS accumulated in the biomass of the acidogenic reactor is desorbed and biodegraded at the same time with an average rate of 39.38 mg/day.

In the methanogenic reactor, LAS tends to bioaccumulate in its biomass at an average rate of 30.18 mg/day (experiment III). While, when it was suspended during experiment IV, both reactors presented a similar desorption-biodegradation behavior in the order of 14.28 mg/d. A greater accumulation trend is observed in the acidogenic reactor at 55.97 mg/d (experiment V), compared to the methanogenic reactor, which was 3.44 mg/d, which is probably explained by the fact that although the biomass of the methanogenic reactor is more sensitive to the presence of LAS, the acetate produced during acetogenesis contributed to the methanogenic reactor in the biodegradation of LAS.

On the other hand, by increasing the concentration of LAS to 300 ± 0.05 mg/L during experiment VI, a similar tendency of LAS accumulation is seen in the biomass of both reactors, this being 29.41 mg/d in the acidogenic reactor and 21.07 mg/d in the biomass of the methanogenic reactor. When the LAS was definitively suspended from the acidogenic reactor feed, a significant difference was observed in the desorption-biodegradation rates of the LAS in both reactors, being of the order of 28.05 mg/d in the acidogenic reactor and 44.35 mg/d in the methanogenic reactor.

This suggested that once the biomass of the methanogenic reactor was acclimated to the presence of the surfactant, it was able to biodegrade the accumulated LAS faster than the biomass of the acidogenic reactor. The acclimatization strategy used is a key factor in achieving the biodegradation of recalcitrant and difficult-to-biodegrade compounds.

Box 7

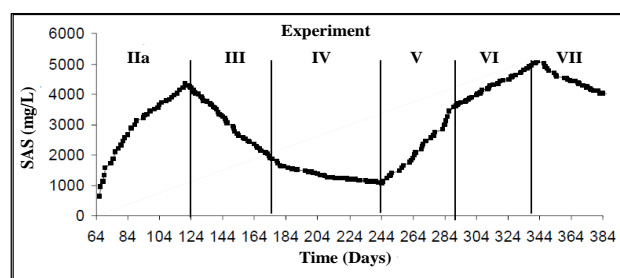

Figure 4

Trend in the accumulation of the anionic surfactant sodium alkylbenzene sulfonate (LAS) in acidogenic reactor sludge

Box 8

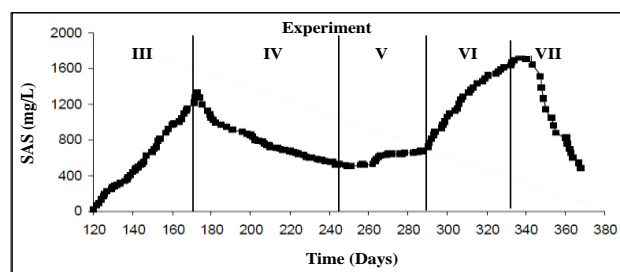

Figure 5

Trend in the accumulation of the anionic surfactant sodium alkylbenzene sulfonate (LAS) in methanogenic reactor sludge

The bioavailability of LAS, and that of other non-ionic surfactants, has been reported to be low as a result of adsorption to solids and dissolved organic matter (Buhl & Hamilton, 2000). LAS persists in anaerobic environments such as aquatic sediments and digester sludge, and is not degraded under anaerobic conditions (Federle & Schwab, 1992). Under anaerobic conditions (Maurer, 1965), it was shown that there is no LAS degradation, but an inhibition of methanogenesis does occur at a concentration of 214 mg/L.

The LAS was not degraded by this route, leading to its accumulation, which probably decreased biomass production and consequently caused a loss of COD removal efficiency. A greater accumulation of LAS was observed in the acidogenic reactor in relation to the methanogenic reactor, despite this, the acidogenic bacteria did not decrease their metabolic activity as much as the methanogenic bacteria.

It is worth mentioning that during the stages in which the LAS was suspended from the acidogenic reactor feed, a remnant was observed in the effluent of both the acidogenic reactor and the methanogenic reactor, taking an average of 16 days for the activity of the acidogenic bacteria to recover and 36 days for the methanogenic bacteria.

Tables 7 and 8 show the LAS balance in the acidogenic and methanogenic reactors, respectively.

Box 9

Table 4

Balance del surfactante en el reactor acidogénico

mg/L	I	IIa	IIb	III	IV	V	VI	VII
LAS _{INFLUENTE}	11400	10000		9000	15600			
LAS _{EFLUENTE}	2208.25	2567.05	*861.31	1201.10	3506.31	*841.45	*284.05	
LAS _{ACUMULADO}	4355.38	1912.4	1051	3569.57	5099.01	4257.56	3973.51	
LAS _{BIODEGRADADO}	4836.37	6120.55		4229.33	6994.68			

*Se contempló dentro del LAS acumulado para hacer el balance.

☒ No hubo presencia de LAS

Box 10**Table 5**

Balance del surfactante en el reactor metanogénico

mg/L	I	IIa	IIb	III	IV	V	VI	VII
LAS _{INFLUENTE}			5796.31	2266.80	2936.95	7813.43	2065.60	
LAS _{EFLUENTE}			1574.48	560.08	857.49	2238.86	712.41	
LAS _{ACUMULADO}			1341.72	524.71	679.84	1808.65	478.14	
LAS _{BIODEGRADADO}			2880.11	1182.01	1399.62	3765.92	875.05	

No hubo presencia de LAS

Suspende el LAS del influente del primer reactor del sistema estudiado

Therefore, it is necessary to consider sustainable and affordable sanitation designs such as the proposal for communities in the San Cristóbal parish, Paute Canton, Azuay Province (Sananay *et al.*, 2025).

Conclusions

The implications are equally relevant at the ecological and agricultural levels. The persistence of detergents in arable soils reduces fertility, alters the soil microbiota, and increases salinity, which can decrease agricultural productivity. In natural ecosystems, the phytotoxicity of detergents causes changes in plant composition, affecting sensitive species and disrupting food chains. There is also a risk of biomagnification, as contaminants accumulated in plant tissues can be transferred to herbivores and, ultimately, to humans if the crops are edible. Furthermore, there is the risk of bioaccumulation in the biomass of UASB-type biological reactors during the treatment of wastewater with high concentrations of surfactants.

Declaration of competing interest

The authors declare that they have no financial conflicts of interest, nor conflicts in personal relationships that could influence the publication of the work presented in this article.

Authors' contributions

All the authors contributed with their experience in the review, analysis and discussion of the results obtained in the study to prepared the manuscript.

Availability of data and materials

I put at your disposal the data obtained in this investigation.

ISSN 2531-2960

RENIECYT: 1702902

ECORFAN® All rights reserved.

Funding

There was no external source of funding for this work.

Acknowledgements

The authors would like to thank the Universidad Tecnológica del Valle de Toluca (UTVT) for providing its laboratory facilities for carrying out this research work.

References**Basics**

Abu-Zreig, M., Rudra R. P. & Dickinson, W. T. (2003). Effect of Application of Surfactants on Hydraulic Properties of Soils. *Biosyst. Eng.* 84 (3), 363-372.

<https://www.scirp.org/reference/referencespapers?referenceid=1063690>

Adekola, B. N. & Eletta, O. A. (2007). A Study of heavy metal pollution of Asa River, Ilorin, Nigeria. *Environmental Monitoring and Assessment*, 12: 157-163. <https://www.scirp.org/reference/referencespapers?referenceid=33532>

APHA, Standard methods for the examination of water and wastewater, 22th edition edited by E. W. Rice, R. B. Baird, A. D. Eaton, L. S. Clesceri, American Public Health Association (APHA), American Water Works Association (AWWA) and Water Environment Federation (WEF), Washington, D.C., USA 2012. https://books.google.com.mx/books/about/Standard_Methods_for_the_Examination_of.html?i=d=dd2juAAACAAJ&redir_esc=y

Badot, P.M. & Garrec, J.P. (1993). Dépérissement local du Pin d'Alep (*Pinus halepensis*) le long du littoral méditerranéen, *Revue Forestière Française*. 2, 134-140. <https://doi.org/10.4267/2042/26404>

Bandala, E.R., Peláez, M.A., Salgado, M.J., Torres, L. (2008). Degradation of sodium dodecyl sulphate in water using solar driven Fenton-like advanced oxidation processes. *Journal of Hazardous Materials*, 51(2-3), 578-84. <https://doi.org/10.1016/j.jhazmat.2007.06.025>

Terreros, Jesús, Velazquez, Gisela and Muriel, Frank. [2025]. Environmental impact of wastewater discharges containing surfactants and their effect on biomass in anaerobic reactors during treatment. *Journal of Technological Development*. 9 [22] 1-16: e40922116 <https://doi.org/10.35429/JTD.2025.9.22.4.1.16>

- Berna, J.L., Moreno, A., Ferrer, J., Prats, D. & Ruiz, F. (1991). The behaviour of LAS in the environment, *J. Chem. Tech. Biotechnol.* 50 (1991) 387-398. <https://doi.org/10.1002/JCTB.280500310>
- Bressan, M., Marin, M.G. & Brunneti, R. (1991). Effect of linear alkylbenzene sulfonate (LAS) on Skeletal Development of Sea Urchin Embryos (*Paracentrotus lividus* LMK), *Wat. Res.* 25, 613-616. [https://doi.org/10.1016/0043-1354\(91\)90134-C](https://doi.org/10.1016/0043-1354(91)90134-C)
- Buhl, K. & Hamilton, S. (2000). Acute toxicity to fire-control chemicals, nitrogenous chemicals, and surfactants to rainbow trout. *Transactions of the American Fisheries Society.* 129: 408-418. <https://www.usgs.gov/publications/acute-toxicity-fire-control-chemicals-nitrogenous-chemicals-and-surfactants-rainbow>
- Cárdenas, G.L. & Sánchez, I.A. (2013). Nitrógeno en aguas residuales: orígenes, efectos y mecanismos de remoción para preservar el ambiente y la salud pública. *Universidad y Salud,* 15(1), 72-88. http://www.scielo.org.co/scielo.php?script=sci_arttext&pid=S0124-71072013000100007
- CENIPALMA. Centro de Investigaciones en Palma de Aceite. (2005). Oleoquímica. <http://cenipalma.org/oleoq.htm>.
- Cirelli, A.F. & Ojeda, C. (2008). Wastewater management in Greater Buenos Aires, Argentina, *Desalination.* 218, 52-61. <https://doi.org/10.1016/j.desal.2006.10.040>
- Cuevas, R.E., Grosskelwing, G., Escobar, O.J. & Cabrera, A. (2023). Efecto fitotóxico de productos de limpieza comerciales sobre la germinación y crecimiento inicial de melotria scabra (sandía de ratón). *Revistas.milpaalta.tecnm.mx,* 6(2), 17-23. <https://dialnet.unirioja.es/servlet/autor?codigo=6500830>
- Dehghani, M.H., Najafpoor, A.A., □ Azam, K. (2010). Using sonochemical reactor for degradation of LAS from effluent of wastewater treatment plant. *Desalination,* 250(1), 82-86. <https://doi.org/10.1016/j.desal.2009.05.011>
- European Eco-Label. (2002). Revision of Eco-label Criteria for Laundry Detergents, DHI Water & Environment dk Teknik, Energy & Environment. <https://www.researchgate.net/publication/215833562>
- Fox, K., Holt, M., Daniel, M., Buckland, H. & Guymer, I. (2000). Removal of linear alkylbenzene sulfonate from a small Yorkshire stream: contribution to greater project 7, *Sci. Total Environ.* 251, 265-275. [https://doi.org/10.1016/S0048-9697\(00\)00389-2](https://doi.org/10.1016/S0048-9697(00)00389-2)
- Genisel, M., & Eren, O. (2020). Evaluación de la aberración fisiológica y bioquímica relacionada con el efecto del dodecilsulfato de sodio en plántulas de cebada. *SN Applied Sciences,* 2, 514. <https://doi.org/10.1007/s42452-020-2289-z>
- Gomes, I.B., Simões, L.C. & Simões, M. (2018). The effects of emerging environmental contaminants on *Stenotrophomonas maltophilia* isolated from drinking water in planktonic and sessile states. *Science of The Total Environment,* 643(), 1348-1356. <https://doi.org/10.1016/j.scitotenv.2018.06.263>
- Hashim, M.A., Kulandi, J. & Hassan, R.S. (1992). Biodegradability of Branched Alkylbenzene Sulphonates, *J. Chem. Tech. Biotechnol.* 54, 207-214. <https://doi.org/10.1002/jctb.280540302>
- Hernández-Baranda, Y. (2023). Effect of detergents on the germination and initial growth. *Revista Colombiana de Ciencias Hortícolas.* <https://www.scielo.org.co/pdf/rcch/v17n3/2011-2173-rcch-17-03-e16577.pdf>
- INEGI (Instituto Nacional de Estadística, Geografía e Informática). La industria química en México (2013). https://www.inegi.org.mx/contenido/productos/prod_serv/contenidos/espanol/bvinegi/producto_s/integracion/sociodemografico/Quimica/2013/702825060503.pdf
- Ivanković, T. & Hrenović, J. (2010). Surfactants in the Environment. *Archives of Industrial Hygiene and Toxicology,* 61(1), 95-110. <https://doi.org/10.2478/10004-1254-61-2010-1943>

- Jardak, K., Drogui, P. & Daghrir, R. (2016). Surfactants in aquatic and terrestrial environment: occurrence, behavior, and treatment processes. *Environmental Science and Pollution Research*, 23(4), 3195–3216. <https://link.springer.com/article/10.1007/s11356-015-5803-x>
- Johnson, P., Trybala, A., Starov, V. & Pinfield, V. (2021). Effect of synthetic surfactants on the environment and the potential for substitution by biosurfactants. *Advances in Colloid and Interface Science*, 288, 102340. <https://doi.org/10.1016/j.cis.2020.102340>
- Korshenko, A. & Gul, A.G. (2005). Pollution of the Caspian Sea. pp: 109-142. In: Kostianov, A.G. and Kosarev, A. N. (ed.), *Handbook of Environmental Chemistry*, Springer Verlag Berlin, pp 109-142. <https://www.researchgate.net/publication/225616801>
- Korzenowski, C., Martins, M.B., Bernardes, A.M., Ferreira, J.Z., Duarte, E.C. & De Pinho, M.N. (2012). Removal of anionic surfactants by nanofiltration, *Desalin. Water Treat.* 44, 269-275. <https://doi.org/10.1080/19443994.2012.691761>
- Lado, M. & Ben-Hur, M. (2009). Treated domestic sewage irrigation effects on soil hydraulic properties in arid and semiarid zones: A review, *Soil Tillage Res.*, vol. 106, no. 1, pp. 152-163. <https://www.sciencedirect.com/science/article/abs/pii/S0167198709000993>
- Lewis, M.A. (1990) Chronic toxicities of surfactants and detergent builders to algae: a review and risk assessment. *Ecotoxicology and Environmental Safety*, 20(2), 123–140. [https://www.wellesu.com/10.1016/0147-6513\(90\)90052-7](https://www.wellesu.com/10.1016/0147-6513(90)90052-7)
- Maloney, James O. (2008). *Perry's Chemical Engineers' Handbook*. Ed. McGraw-Hill <https://archive.org/details/perryschemicalengineershandbookmcgrawhill8thed2008>
- Marin, R. (1995). Compuestos orgánicos en las aguas presencia e importancia, *Rev. Ing. Quim.* 314, 159-165. <https://dialnet.unirioja.es/servlet/articulo?codigo=4616089>
- Misra, R.K. & Sivongxay, A. (2009). Reuse of laundry greywater as affected by its interaction with saturated soil. *J. Hydrol.* 366 (1-4), 55-61. <https://www.sciencedirect.com/science/article/abs/pii/S0022169408006161>
- Mogensen, A.S., Haagen, F., Ahring, B.K., 2003. Anaerobic degradation of linear alkylbenzene sulfonate. *Environ. Toxicol. Chem.* 706–711. <https://orbit.dtu.dk/en/publications/anaerobic-degradation-of-linear-alkylbenzene-sulfonate>
- Mousavi, S. & Khodadoost, F. (2019). Effects of detergents on natural ecosystems and wastewater treatment processes: a review. *Environmental Science and Pollution Research*, 26(26), 26439–26448. <https://pubmed.ncbi.nlm.nih.gov/31352596/>
- Naldoni, A., Schiboula, A., Bianchi, C. L., & Bremner, D. (2011). Mineralisation of surfactants using ultrasound and the advanced Fenton process. *Water, Air, & Soil Pollution*, 215, 487–495. <https://link.springer.com/article/10.1007/s11270-010-0493-y>
- Pérez-García, L.A. (2023). La bioacumulación de metales pesados y el desarrollo de la agricultura. *Revista Cubana de Salud Ambiental*, 23. https://scielo.sld.cu/scielo.php?pid=S1993-80122023000300174&script=sci_arttext
- Pettersson, A., Adamsson, M. & Dave, G. (2000). Toxicity and detoxification of Swedish detergents and softener products. *Chemosphere*, 41(10), 1611–1620. <https://www.sciencedirect.com/science/article/abs/pii/S0045653500000357>
- Procter & Gamble México. (2025). Ariel detergente México: Posicionamiento de marca y estrategias de crecimiento. P&G México. <https://www.economista.com.mx/empresas/Mexico-es-uno-de-nuestros-mercados-con-mas-crecimiento-PG-20230517-0146.html>
- Rebello, S., Asok, A., Mundayoor, S. & Jisha, M. (2013). Surfactants: Chemistry, toxicity and remediation. *Environmental Chemistryfor a Sustainable World*, 4, 277–320. https://doi.org/10.1007/978-3-319-02387-8_5

Research Report (2024). Surfactants Industry Research.

https://pdf.marketpublishers.com/apo_research/surfactants-industry-research-report-2024.pdf

Rosety-Rodríguez, M., Ordonez, F.J., Roldan, S., Rosety, J.M., Rosety, M., Ribelles, A., Carrasco, C. & Rosety, I. (2002). Acute effects of sodium dodecyl sulfate on the survival and on morphohistochemical characteristics of the trunk kidney of juvenile turbot *Scophthalmus maximus*, L. *European journal of histochemistry*, 46, 179-184. <https://doi.org/10.4081/1668>.

Sharma P, Jha A.B., Dubey, R.S. & Pessarakli, M. (2012). Reactive oxygen species, oxidative damage, and antioxidative defense mechanism in plants under stressful conditions. *J Bot*, 1–26. <https://doi.org/10.1155/2012/217037>

Shelton, D.R. & Tiedje, J.M. (1984). General method for determination anaerobic biodegradation potencial, *Appl. Microbiol. Biotechnol.* 47, 850–857. <https://doi.org/10.1128/AEM.47.4.850-857.1984>.

Uning, R., Suratman, S., Latif, M. & Mustaffa, N. (2022). Assessment on the distributions and exchange of anionic surfactants in the coastal environment of Peninsular Malaysia: A review. *Environmental Science and Pollution Research*, 29(11), 15380–15390. <https://doi.org/10.1007/s11356-021-18395-1>

Van Hamme, J.D., Singh, A. & Ward, O.P. (2006). Physiological aspects. Part 1 in a series of papers devoted to surfactants in microbiology and biotechnology. *Biotechnology Advances* 24, 604–620. <https://www.scirp.org/reference/referencespapers?referenceid=3528130>

Vázquez, A. C. (2024). Efecto fitotóxico de detergente y bismuto sobre la germinación y crecimiento inicial de *Melotria scabra*. *CITT*. <https://citt.itsm.edu.mx/ingeniantes/articulos/ingeniantes11no2vol1/03%20-25-31.pdf>

WHO/UNICEF (2015). Joint Monitoring Program for Water Supply and Sanitation (JMP). <https://www.unwater.org/publications/who/unicef-joint-monitoring-program-water-supply-and-sanitation-jmp-2015-update>

World Bank Group. (2020). El agua residual puede generar beneficios para la gente, el medioambiente y las economías, según el Banco Mundial. World Bank Group. <https://www.bancomundial.org/es/news/press-release/2020/03/19/wastewater-a-resourcethat-can-pay-dividends-for-people-the-environment-and-economies-says-world-bank>

Zhu, F.J., Ma, W.L., Xu, T.F., Ding, Y., Zhao, X., Li, W.L., Liu, L.Y., Song, W.W., Li, Y.F. & Zhang, Z.F. (2018). Removal characteristic of surfactants in typical industrial and domestic wastewater treatment plants in Northeast China, *Ecotoxicol. Environ. Saf.* 153, 84-90. <https://doi.org/10.1016/j.ecoenv.2018.02.001>

Zhuravel, V. E., Bezerbnaya, I.P. & Buzoleva, S.L. (2004). Microbial indication of pollution of the coastal zone of the sea of Okhotsk and Avacha Bay. *Russian Journal of Marine Biology*, 30 (2): 121-126. <https://link.springer.com/article/10.1023/B:RU MB.0000025988.87193.c2>

Differences

Terreros-Mecalco, J., Guzman-Lopez, O., & García-Solorio, L. (2022). Simultaneous aerobic-anaerobic biodegradation of an industrial effluent of polymeric resins with high phenol concentration at different organic loading rates in a non-conventional UASB type reactor. *Chemical Engineering Journal*, 430, 133180. <https://www.sciencedirect.com/science/article/abs/pii/S1385894721047562>

Discussions

Buhl, K. & Hamilton, S. (2000). Acute toxicity to fire-control chemicals, nitrogenous chemicals, and surfactants to rainbow trout. *Transactions of the American Fisheries Society*. 129: 408-418. <https://www.usgs.gov/publications/acute-toxicity-fire-control-chemicals-nitrogenous-chemicals-and-surfactants-rainbow>

Costello, D.J., Greefield, P.F., Lee, P.L., 1991. Dynamic modelling of a single stage high rate anaerobic reactor-I, Model derivation. *Water Res.* 25, 847–871. [https://doi.org/10.1016/0043-1354\(91\)90166-N](https://doi.org/10.1016/0043-1354(91)90166-N)

Federle W.T and Schwab B.S. (1992). Mineralization of surfactants in anaerobic sediments of a laundromat wastewater pond. *Wat. Res.* 26: 123-127.

<https://www.sciencedirect.com/science/article/abs/pii/004313549290121J>

González-Mazo E., Forja, J.M. & Gómez-Parra, A. (1998). Fate and Distribution of Linear Alkylbenzene Sulfonates in the Littoral Environment. *Environ. Sci. Technol.* 32, 1636-1641.

https://www.researchgate.net/publication/231290836_Fate_and_Distribution_of_Linear_Alkylbenzene_Sulfonates_in_the_Littoral_Environment

Lorenzo, Y. & Obaya, M.C (2005). La Digestión anaerobia, aspectos teóricos parte 1. ICIDCA. Sobre los Derivados de la Caña de Azúcar, vol. XXXIX, núm. 1, 2005, pp. 35-48.

<http://www.redalyc.org/articulo.oa?id=223120659006>

Maurer W., Cordon T.C., Well J.K., Nuñez-Ponzoa M.V., Ault W.C. and Stirton A.J. (1965). The effect of tallow based detergent on anaerobic digestion. *The Journal of the American Oil Chemist Society.* pp: 189-192. <https://link.springer.com/article/10.1007/BF02541129>

McCarty P. L. (1964). Anaerobic waste treatment fundamentals. Part II; Environmental requirements and control. *Public works.* 95 (10), 123.

<https://es.scribd.com/document/717879341/McCarty-1964>

Sananay Auquilla, J. E., Zeas Maza, M. E., & Salas Vázquez, C. A. (2025). Diseño de un sistema descentralizado de saneamiento para comunidades de la parroquia San Cristóbal, Cantón Paute, Provincia del Azuay.

<https://www.dspace.espol.edu.ec/handle/123456789/65857>

Sigoillot J.C. and Nguyen M.H. (1992). Complete Oxidation of linear alkylbenzene sulfonate by Bacterial Communities Selected from Coastal Seawater. *Appl. Environ. Microbiol.* 58: 1308-1312.

<https://pubmed.ncbi.nlm.nih.gov/1599249/>

Swisher R.D. (1981). The problem of Ultimate Biodegradability of linear alkylbenzene sulfonates. An Extension. *Tenside Detergent.* 18: 57-63.

<https://www.degruyterbrill.com/document/doi/10.1515/tsd-1981-180203/html>

Swisher, R.D., 1986. *Surfactant Biodegradation*, second ed. E.E.U.U, Marcel Dekker, New York, Inc. Nueva York (Chapter 1), section II. https://books.google.com.mx/books/about/Surfactant_Biodegradation_Second_Edition.html?id=G56_-HYey9IC&redir_esc=y

Terreros-Mecalco, J., Guzman-Lopez, O., & García-Solorio, L. (2022). Simultaneous aerobic-anaerobic biodegradation of an industrial effluent of polymeric resins with high phenol concentration at different organic loading rates in a non-conventional UASB type reactor. *Chemical Engineering Journal*, 430, 133180. <https://www.sciencedirect.com/science/article/abs/pii/S1385894721047562>

Thiele, J.H., Chartrain, M. & Zeikus, G. (1988). Control of interspecies electron flow during anaerobic digestion: role of floc formation in syntrophic methanogenesis. *Appl. Environ. Microbiol.* 54 (1): 10-19. <https://europepmc.org/backend/ptpmrender.fcgi?accid=PMC202390&blobtype=pdf>

Wagener S. & Schink B. (1988). Fermentative degradation of nonionic surfactants and polyethylene glycol by enrichment cultures and by pure cultures of homoacetogenic and propionate forming bacteria. *Appl. Environ. Microbiol.* 54: 561-565. <https://pubmed.ncbi.nlm.nih.gov/3355141/>

Wolf, W., Feijtel, T., 1998. Terrestrial Risk Assessment for linear alkylbenzene sulfonate (LAS) in sludge-amended solids. *Chemosphere* 36, 1319–1343. [https://doi.org/10.1016/S0045-6535\(97\)10021-2](https://doi.org/10.1016/S0045-6535(97)10021-2)

Wosman, A., Lu, Y., Sun, S., Liu, X., Wan, C., Zhang, Y., Lee, D.J., Tay, J., 2016. Effect of operational strategies on activated sludge acclimation to phenol, subsequent aerobic granulation and accumulation of polyhydroxyalkanoates. *J. Hazard Mater.* 317, 221–228.

<https://doi.org/10.1016/j.jhazmat.2016.05.074>.

Perception of electricity service quality and its impact on local development. Study in Jalpan de Serra, Querétaro

Percepción de la calidad del servicio eléctrico y su impacto en el desarrollo local. Estudio en Jalpan de Serra, Querétaro

Morado-Huerta, Ma Guadalupe*^a, Márquez-Hernández, Olga^b, López-Hernández, Edgardo^c and Ibarra-Pérez, Juan^d

^a  Universidad Tecnológica de San Juan del Río •  KSM-5439-2024 •  0000-003-0029-4208 •  251130

^b  Universidad Tecnológica de San Juan del Río •  KVD-8914-2024 •  0009-0002-6034-6372 •  2043482

^c  Universidad Tecnológica de San Juan del Río •  KUT-9920-2024 •  0009-0008-9710-7520 •  1292480

^d  Universidad Tecnológica de San Juan del Río •  KUX-7503-2024 •  0009-006-2921-1348 •  313106

Classification:

Area: Engineering
Field: Technological sciences
Discipline: Energy technology
Subdiscipline: Other

 <https://doi.org/10.35429/JTD.2025.9.22.5.1.11>

History of the article:

Received: June 13, 2025

Accepted: December 10, 2025

*  [\[mgmoradoh@utsjr.edu.mx\]](mailto:mgmoradoh@utsjr.edu.mx)



Abstract

The study analyzes the perceived quality of electric service in Jalpan de Serra, Querétaro and its impact on local development. The research examines the main defects of the electric service, its effect on daily activities and the causes of energy problems in the region. A total of 370 surveys were administered to inhabitants over 18 years of age. As a result, 50% of the population considers the electricity supply to be reliable, while 40% expressed dissatisfaction. The main causes of interruptions are maintenance and work on the electrical grid. At the economic level, it was identified that electrical failures generate premature wear of equipment and significant losses in households. Inhabitants identify natural disasters, technical failures and maintenance work as the main causes. The study proposes alternatives such as hybrid solar energy systems, microgrids and renewable energy cooperatives to improve the quality of supply in rural areas.

Resumen

El estudio analiza la calidad percibida del servicio eléctrico en Jalpan de Serra, Querétaro y su impacto en el desarrollo local. La investigación examina los principales defectos del servicio eléctrico, efecto en las actividades cotidianas y causas de los problemas energéticos en la región. Se aplicaron 370 encuestas a habitantes mayores de 18 años. Obteniendo como resultado que el 50% de la población considera confiable el suministro eléctrico, mientras que el 40% manifiesta inconformidad. Las principales causas de interrupciones son los mantenimientos y trabajos en la red eléctrica. A nivel económico, se identificó que las fallas eléctricas generan desgaste prematuro de equipos y pérdidas significativas en los hogares. Los habitantes identifican como principales causas los desastres naturales, fallas técnicas y trabajos de mantenimiento. El estudio propone alternativas como sistemas híbridos de energía solar, micro redes y cooperativas de energías renovables para mejorar la calidad del suministro en zonas rurales.

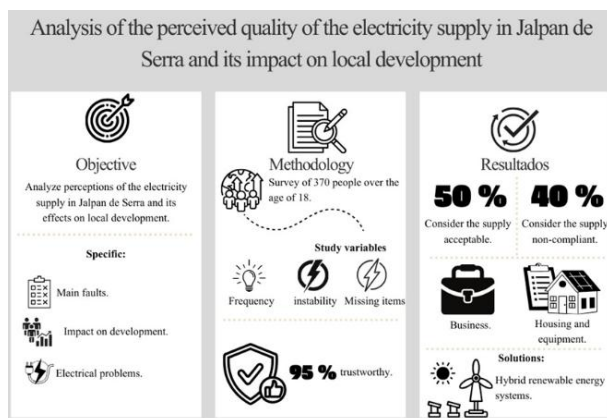

Quality of electrical service, Local development, Public perception



Calidad del servicio eléctrico, Desarrollo local, Percepción ciudad

Area: Development of strategic leading-edge technologies and open innovation for social transformation

Citation: Morado-Huerta, Ma Guadalupe, Márquez-Hernández, Olga, López-Hernández, Edgardo and Ibarra-Pérez, Juan. [2025]. Perception of electricity service quality and its impact on local development. Study in Jalpan de Serra, Querétaro. Journal of Technological Development. 9 [22] 1-11: e50922111



ISSN 2531-2960/© 2009 The Authors. Published by ECORFAN-México, S.C. for its Holding Spain on behalf of Journal of Technological Development. This is an open-access article under the license CC BY-NC-ND license [<http://creativecommons.org/licenses/by-nc-nd/4.0/>]

Peer review under the responsibility of the Scientific Committee MARVID® in the contribution to the scientific, technological and innovation Peer Review Process through the training of Human Resources for the continuity in the Critical Analysis of International Research.



Introduction

It is important to analyze the impact of the variability in the electric service in the country, since it can provide an overview of the perception that the inhabitants have regarding a service that is assumed to arrive regularly to the localities that have it, such as electric energy. However, the lack of knowledge about the technical operation of the energy system in Mexico, causes the population to measure the impact of the failure only at the level of cost and comfort, leaving aside the possible evaluation in the adoption of new ways of having the service. Together with a government policy that allows a solution to the case, this phenomenon is becoming increasingly complex.

The contribution of this study lies in the options identified to provide a solution to the situation in the medium term, giving an overview of the current perception of the inhabitants and the situation surrounding the solution to the problem.

First of all, the main electricity supply problems identified by the inhabitants of Jalpan de Serra are identified, as well as how these affect the development of their daily activities, to later give way to the perception of the factors that contribute to the proper functioning of this service.

A priori it can be felt in the daily coexistence the high dissatisfaction that the area shows given the constant power outages and the economic impacts that this has on the various sectors of the population.

The theoretical approach of this document consists of identifying the characteristics of the subject under study from the perspective of a user, not in a technical way as the discipline of energy studies does. This allows understanding how the perception of energy service quality can be measured in colloquial terms, on the other hand, consumption and infrastructure data are added to help understand the context of the place where the instrument is applied, as well as in the same order of ideas, rural development and the impact of the quality of supply in these areas are circumscribed.

Regarding the findings of this research and the perception of the quality of service, it is mentioned that the inhabitants show a fifty percent of satisfaction and the rest in satisfied mode, being the main concerns about the interruptions that the service has and the economic impact that these represent.

Finally, it is concluded that the Sierra Gorda needs to implement alternatives for the solution to this situation, which leads its localities to lag behind in development and makes the possibilities of a better quality of life more expensive, together with the need for energy supply given the changes in the climate that make the hot season more and more acute in the area. Some alternatives derived from the documentary analysis on the subject are proposed, in which the modalities of sustainable energy cooperatives are visualized.

Theoretical support

Quality of energy supply

This refers to the capacity of the energy to remain stable continuously, that is to say, that it has the adequate voltage and frequency capacities to avoid damage to the inhabitants' electrical equipment, which ensures the proper functioning of daily activities. Likewise, this quality depends on several factors, such as infrastructure, adequate maintenance and the generation capacity of the power supply. Therefore, it is deduced that the increase in the number of loads in the distribution systems is a cause of the degradation of the quality of electric power.

In this sense and in order to have an improvement in the quality of energy supply, the possibility of conducting an analysis to evaluate the impact of the implementation of alternative energy sources that improve the quality conditions of energy supply is not ruled out, according to [Rodríguez et al . \(2018\)](#).

According to the media, [Expreso de Querétaro \(2025\)](#) e in Jalpan de Serra the quality of the energy supply is deficient, that is to say, it generates blackouts, voltage variations, overloads and damages to the users' equipment, which has been analyzed by the Energy Agency of the State of Querétaro, thus, taking a proposal to the Federal Electricity Commission, the above to propose substantial improvements in this service.

Current situation of energy supply in Jalpan

Jalpan de Serra is a municipality in the Sierra Gorda of Querétaro that is characterized by its mountainous geography, which makes infrastructure difficult. Most of its communities are small and scattered, which hinders the proper distribution of energy. In addition, its economy depends mainly on agriculture, livestock and tourism, so these sectors depend on a reliable energy supply for their development.

In the digital media there are notes that mention the improvement of the power grid, which occurs in a context of deficiencies in the quality of electricity supply. An example is the news item "CFE started electrical modernization in Jalpan de Serra", published in [Código Querétaro, written reality \(2024\)](#).

On the other hand, on the website of the [Municipio de Jalpan de Serra \(2025\)](#), only mentions a management for the improvement of the electric service and an adjustment of the rates given the weather conditions. "Gobierno municipal y CFE revisan acciones clave para mejorar el servicio eléctrico en Jalpan".

Therefore, no action is identified that would lead to an improvement of the current conditions.

On the other hand, the media [Expreso Querétaro \(2025\)](#) mentions the document called "Technical Report", which details the actions to be carried out to improve the electric service in the area. This is how Queretaro seeks to solve the lack of electricity in the Sierra Gorda", which mentions the existence of a feasibility document generated by the Energy Agency of the State of Queretaro and submitted to the CFE, which includes the recalibration and reinforcement of power lines, the replacement of deteriorated poles, the expansion of distribution networks and an increase in the capacity of transformers, and which seeks to provide a solution to the quality of service received in the mountainous area. Access to this document is not documented on the energy agency's website.

Based on the aforementioned information, there is currently no plan in place to improve these conditions. However, it is necessary for the authorities to design a public policy to address these needs.

Energy infrastructure and challenges

The national electricity system is composed of power plants of different technologies, the National Transmission Network (RNT) and the General Distribution Networks (RGD), which deliver the electricity produced in the power plants to Basic Service Users (USB) and Market Users (UM).

At the state level, energy consumption is concentrated in industry and medium voltage businesses, followed by residential users and industrial users, with agricultural users occupying a smaller place, according to data from the [Secretaría de Energía \(2022\)](#).

With data from the [Secretaría de Energía \(2022\)](#), the following table has been prepared, which shows electricity consumption in MWh (megawatt-hour) for Jalpan de Serra, Landa de Matamoros, Pinal de Amoles and Arroyo Seco.

Box 1

Table 1

Consumption in MWh by municipality

Municipality	Residential Consumption in MWh		Commercial Consumption MWh	
Jalpan de Serra	13258.281	38%	3517.093	51%
Landa de Matamoros, Querétaro	8140.1	23%	975.269	14%
Pinal de Amoles	7049.226	20%	925.264	13%
Arroyo Seco	6462.362	19%	1484.25	22%
Total Sierra Gorda	34909.969		6901.876	

Source: Own elaboration with data from [Secretaría de Energía \(2022\)](#)

The grids in Jalpan de Serra come from the national grids which transport energy from more urbanized centers to the municipality that extend from the more urbanized areas by it is necessary to transport energy through medium and low voltage transmission grids, which supply both urban and rural areas of the municipality. In addition, many of the components of the electrical infrastructure, such as poles and transformers, are aging, which causes frequent power failures, these problems not only affect domestic activities, but also the economic development of the region, especially in agricultural and tourism sectors, which depend on a stable electricity supply.

Security in the quality of the energy service

According to the [Dirección General de Comunicación de la UNAM \(2025\)](#), "The lack of access to conventional energy makes some people resort to other sources for lighting or electricity". In these cases, kerosenes, diesel fuels (diesel) and other gas lamps are generally used, so the use of these alternatives has important consequences in terms of cost, safety and environmental damage.

As mentioned above, security of electricity supply includes not only the physical protection of the infrastructure, but also ensuring that energy supplies do not put the population at risk. Power outages can affect inhabitants, especially when they affect street lighting and home security. Thus, the inappropriate use of power generators or other alternative sources, such as light generators, gas lamps, diesel, among others, during power outages can pose additional risks to the population.

Rural areas experience high population growth and accelerated urbanization, which contributes to environmental disruption. In other words, no source of electricity generation is free from producing environmental impacts. In terms of emissions of pollutants into the atmosphere, small amounts of radioactive materials are released, which considerably affect climatological aspects, according to [Campos and Quintanilla \(1997\)](#). This causes storms, rains and floods that can damage power lines and cause unexpected blackouts that can last for days without a response from a company in charge, so the adoption of renewable energy sources can help decrease these risks and maximize quality in the home.

Reliability of energy supply

Rural areas require high power availability with unlimited supply that does not interfere with daily tasks, business or grid connections to enable remote working. Network availability is the goal of telecommunication companies in rural areas to try to provide the same quality of service as in large cities ([enerTIC, 2022](#)). The reliability of the electric service is a concern, as blackouts are frequent and disrupt the daily lives of the inhabitants. In communities near Jalpan de Serra, the reliability of the power supply is often lower than in urban areas due to the lack of investment in it.

The frequency of blackouts is high and the response time of companies to these incidents is late, so these are indicators that allow us to evaluate the reliability of the electricity system.

Energy and rural development

Energy is an important factor for the progress of communities in areas such as health, education and production. In most communities in Jalpan de Serra, access to electricity supply is limited, which affects their development. To this end, the use of renewable energies can be implemented to reach communities where the electricity grid is scarce, especially if we take into account that Querétaro is a state with great potential in renewable energies, such as solar and wind ([Cruz y Vargas, 2021](#)).

It could be said that renewable energies, such as solar and wind, are fundamental to achieve a sustainable electricity supply in the communities of Jalpan de Serra, since they allow reducing the excessive use of electricity and using it more efficiently. The use of these types of energy sources is that they are cleaner and more sustainable, and would also help improve the quality of supply and reduce the environmental impacts associated with commonly used energy sources.

Renewable energies, such as solar and wind, represent a viable option for improving the quality of energy supply in remote rural communities. Due to the growing demand for energy in Mexico, it is possible to analyze and identify alternative energy consumption scenarios, as well as their relationship with the product, prices, possible technological innovation alternatives and their aggregate impact on both the product and prices.

Therefore, the installation of solar panels and small wind turbines in Jalpan de Serra can increase the stability of supply and reduce interruptions, improving the quality of life of the inhabitants.

It should be noted that these alternatives to improve supply are not economically accessible for most rural localities, as they imply high financing costs.

As mentioned by [Zarate \(2022\)](#), the process of transition to renewable energies has stalled in federal public management, which returns electric power to the category of national investment priority as a method of centralizing resources.

Methodology

General Objective:

To analyze the perceived quality of Jalpan de Serra's electricity supply and its impact on local development.

Specific objectives:

1. To identify the main perceived defects of the electrical supply in Jalpan de Serra.
2. To analyze the impact of electrical problems on the daily activities of the inhabitants.
3. To analyze the causes of electrical problems in Jalpan de Serra.

Justification:

The constant blackouts in the municipality of Jalpan de Serra cause interruptions in daily activities, as well as in the safety and well-being of the population.

The constant blackouts in the municipality of Jalpan de Serra cause interruptions in daily activities, as well as in the safety and well-being of the population. It is important to highlight that the present research contributes to identify how the lack of electricity is faced and the availability of opting for alternative energies that support the current deficiency of electricity supply.

Population and sample

The population under study are the people over 18 years of age in the neighborhoods of Jalpan de Serra, estimated according to the Population and Housing Census of INEGI in 9250 inhabitants, from which 370 people will be selected, with a confidence level of 95%.

Variables

The variables defined below are taken from technical studies in the area of electricity, which allow us to determine the elements that constitute the instrument that measures the perceived quality of electricity supply in a specific region. A conceptual definition of these variables is presented below:

Duration of interruptions

It is the total time during which users are left without power supply during a specific period [Pesantez et al., \(2021\)](#).

Electrical stability

Variability of electrical voltage with respect to the voltage levels recommended by technical standards. Voltage stability is essential for the proper functioning of connected electrical equipment [Mercado Polo et al., \(2017\)](#).

Reliability of supply

Capacity of the electrical system to provide energy reliably, minimizing the number of interruptions and unwanted fluctuations [Levy and Carrasco \(2020\)](#).

Technical and non-technical losses

Technical losses: "Occur naturally as a direct result of the physical characteristics of the networks and consist mainly of energy lost during transport and distribution within the electrical network, in the various components of the electrical system: transmission and distribution lines, transformers, metering systems and other equipment".

Non-technical losses: these are losses (not directly related to the physical characteristics of the networks) associated with the amount of electricity associated with the amount of electricity that was supplied but not billed.

Refers to energy losses during transmission and distribution, which can be technical (Joule effect in transmission lines) or non-technical (energy theft, metering errors) according [Herrera \(2004\)](#).

Economic costs

Economic impact derived from electrical problems, including losses due to damage to household appliances and downtime in productive activities [Arrellano and Chapa \(2017\)](#).

Develop give the meaning of the variables in linear writing and important is the comparison of the used criteria.

Results

The following are the results aligned with the objectives of this research related to the variables that were evaluated through the perception of the inhabitants. The results shall be by section of the article.

Box 2

Figure 1
Relationship between variables and objectives

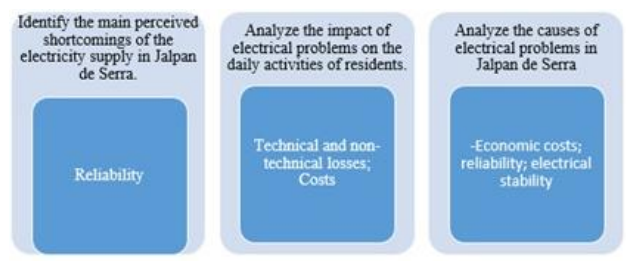

Source: Own Elaboration

Identify the main perceived defects of the electricity supply in Jalpan de Serra.

Associated variable: Reliability of supply

Box 3

Figure 2
Rating of power supply

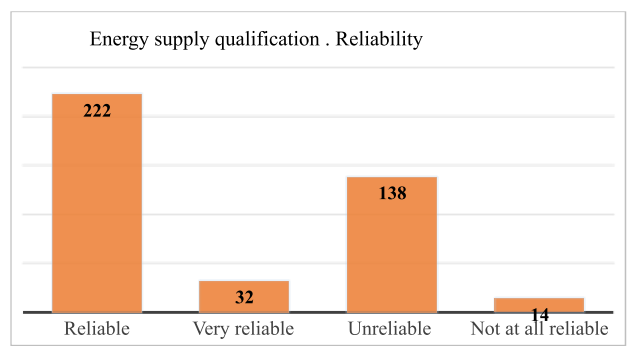

Source: Own Elaboration

Box 4

Figure 3
Causes of supply interruption

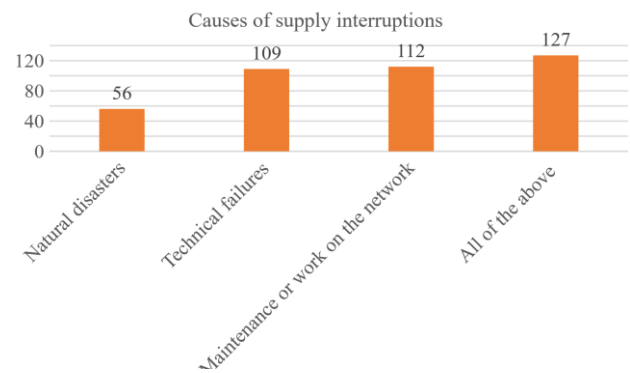

Source: Own elaboration

The instrument shows that fifty percent of the population considers that the electricity supply is reliable, while forty percent indicate that they are not satisfied with it and point out that the main causes of electricity interruptions are maintenance or work on the network. As a result, users have little confidence in the electric system and those who participate in its management.

The reliability of an electric system is measured using methods that not all the inhabitants of a locality are willing to pay for, since the benefit of the service is assumed by the simple fact of residing in a locality with the services.

Therefore, and given the variability of the service, it can be assumed that the situation in some cases can lead to energy poverty, given the difficult access to a totally reliable supply that does not affect the lives of the inhabitants, according to Ceballos et al. (2022)

Objective 2. Analyze the impact of electrical problems on the daily activities of the inhabitants.

Associated variable: Technical and non-technical losses; economic costs.

Box 5

Figure 4

Affected by technical and non-technical losses

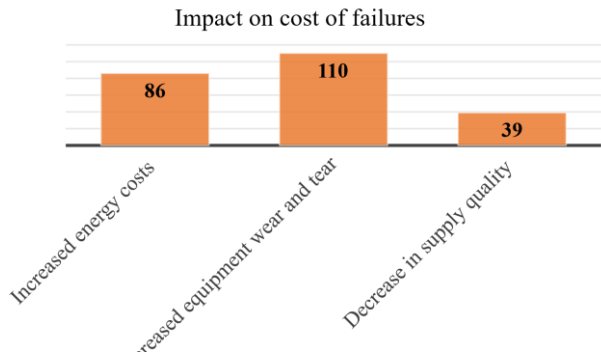

Source: Own Elaboration

Box 6

Figure 5

Economic impact on housing. Costs

Economic impact on housing. Costs

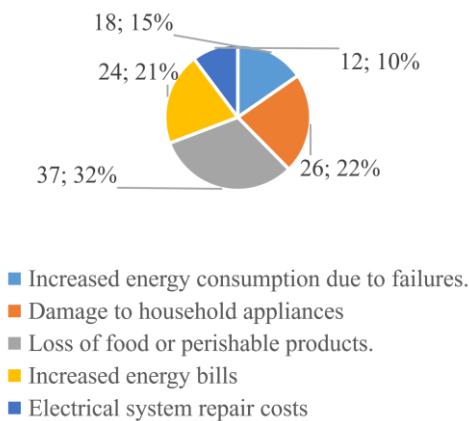

Source: Own Elaboration

The second objective is to analyze the impact of electrical problems in the region. Surveys conducted with the inhabitants show that one of the main problems caused by interruptions in the electricity supply is the premature wear of equipment, which underlines the importance of having a stable electrical system.

These electrical failures are not identified as an isolated event in localities with higher demand, but are national situations that have been occurring since the growth of electricity demand, which in turn is affected by the demand due to economic growth and the development of new industrial parks in specific poles, (Instituto Mexicano de la Competitividad, 2024).

Objective 3. Analyze the causes of electrical problems in the communities of Jalpan de Serra.

Associated variable: Economic costs, Reliability of supply, electrical stability

Box 7

Figure 6

Electrical Stability

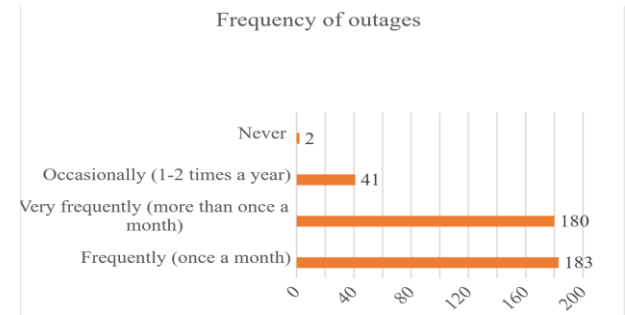

Source: Own Elaboration

Box 8

Figure 7

Cost of blackouts in the last year

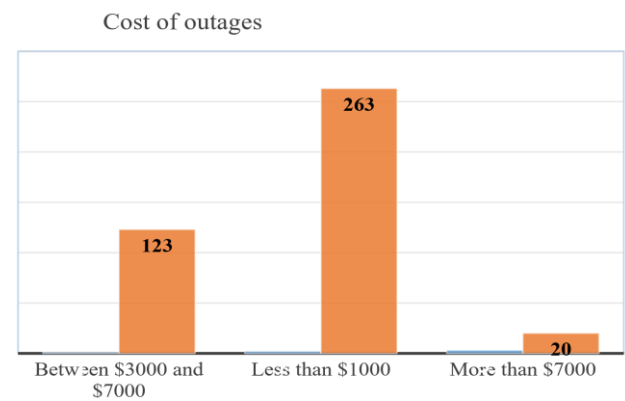

Source: Own elaboration

Box 9

Figure 8

Causes of power outages

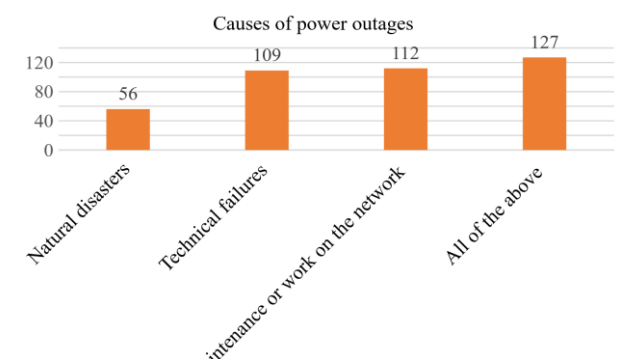

Source: Own Elaboration

Box 10**Figure 9**

Types of costs involved in power outages

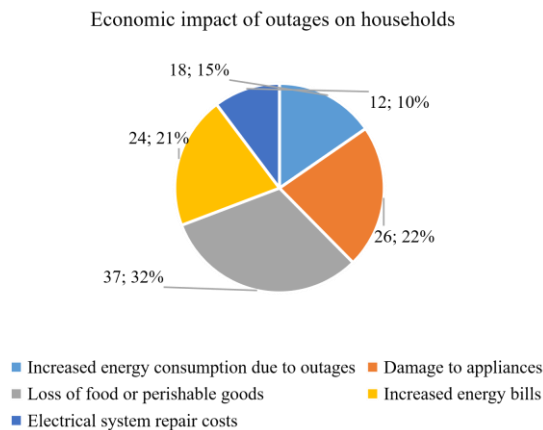
*Source: Own Elaboration*

In order to analyze the causes of electricity problems in the region, respondents were asked to indicate the possible causes of the interruptions. Respondents indicated that these could be due to natural disasters, technical failures, maintenance or work on the grid, which in turn generate significant consequences in households, such as damage to household appliances and loss of food and products that spoil faster due to lack of electricity.

According to research based on electricity supply costs:

"The average selling price of electricity in Mexico is not enough to cover the cost of the service, as it includes the payment of a high leverage. By law, this charge could be used to finance the expansion of the service, but the authorities have preferred to use it to cover other federal government expenses", according to [Rodríguez and Sheinbaum \(2002\)](#).

In turn, it mentions that many users pay a price much higher than the real cost of electricity. If we relate this to our research, this could be due to the large number of failures in the system, which cause the user to be affected by having to pay for a service that does not correspond to him.

Conclusions

Power outages and voltage fluctuations generate dissatisfaction among service users, and challenges related to electricity distribution and transmission continue.

The laws and concessions promoted and halted throughout history by successive federal governments have slowed down the process of adopting alternative energies that would enable the development of some localities and access to a decent standard of living. Added to this is climate change, which entails greater energy demand to cope with its impacts, [Ceballos et al \(2022\)](#).

Although there has recently been a major rollout of fiber optics and new stations that favor digitization, energy has been a highly controllable issue that has been relegated to improving sections of infrastructure that temporarily solve the supply problem.

Currently, the federal government is spearheading a proposal that revisits previous plans and continues with the intention of preserving the country's legacy, as pointed out by [Goldwyn and Hernández \(2025\)](#) in their article "Mexico's new electricity law could boost the country's energy sector. But big questions remain"

On the other hand, it is worth noting some alternatives that can be envisaged in the current scenario of political management and national priorities: a hybrid solar energy and battery system would make it possible to supply the energy needed to meet the demand in these rural areas and offer the quality of life that is needed. The hybrid system is an economical solution for a reliable electricity supply ([Díaz et al, 2022](#)).

Another alternative is a microgrid, which is feasible for remote areas and can complement a hybrid system such as the one mentioned above.

These independent electrical grids allow for energy generation and distribution that increases reliability, quality, and electrical stability, enabling resilience to adverse external factors. According to the "Energy without Borders" project, which analyzes the feasibility of these systems with wind, hydro, and biomass energy alternatives, according to [Alaminos et al \(2013\)](#), these grids can be a solution for remote areas.

Policy management models that solve the energy supply problem are scarce; success stories come from industry, which has sought to solve its problems, such as Grupo Bimbo, which announced that 92% of its global electricity already comes from renewable sources such as solar and wind, and that by 2025 it will consolidate its position as a company that uses 100% renewable electricity in countries such as Mexico, Ecuador, Brazil, South Korea, Guatemala, and China, among others ([Grupo Bimbo, 2023](#)).

There are alternatives on the table, such as renewable energy cooperatives, an option shared by the [Deutsche Gesellschaft für Internationale Zusammenarbeit \(2020\)](#) in its publication *Guide to Sustainable Energy Cooperatives in Mexico*. These function as a tool to promote participation and democratization of energy generation, and are a management and operational option to solve the problem in the medium and long term, especially in the context of the small and medium-scale photovoltaic market. In this sense, they can support the resolution of the energy problem and place the local government of the Sierra Gorda as the coordinator of actions.

Some examples of these cooperatives in Mexico, according to the text [Instituto Nacional de la Economía Social \(2020\)](#), are:

- Onergia: a cooperative that promotes community solar projects, especially in rural and indigenous areas. They work with collective ownership models and local training.
- CEEOAX (Oaxaca Energy and Ecology Cooperative): focused on sustainable solutions for Oaxacan communities, combining renewable energy with ecological practices.
- Báaxal: a cooperative that promotes clean energy projects in the south of the country, with a focus on energy justice.
- Cooperativa Mixta “La Esperanza”: linked to sustainable brick producers, integrating electricity generation with production processes

Declarations

Conflict of interest

The authors declare no interest conflict. They have no known competing financial interests or personal relationships that could have appeared to influence the article reported in this article.

Author contribution

Morado-Huerta, Ma. Guadalupe: Responsible for the research project, research design and data analysis.

Márquez Hernández, Olga: Method drafting.

López Hernández, Edgardo: Theoretical support

Ibarra-Pérez, Juan: Review of publication requirements

Availability of data and materials

The information needed to carry out this work can be found in the research database stored in the institutional drive account.

Funding

Funded by the budget allocated to the research department of the Technological University of San Juan del Río, in accordance with the request made by the Academic Body CA-8 Business, Ecotourism, and Technology of the institution.

Acknowledgements

To the group of students who assisted in data collection, as well as in the baseline study that supported this research.

References

Antecedents

Herrera, M. (2004). [Análisis de pérdidas de energía en el sector de distribución eléctrica](#). *El NoticIEEEro*, 32(1). Panamá: Instituto de Ingenieros eléctricos y electrónicos.

Rodríguez G, M., Vázquez, A., Velés, A., y Manuel, S. W. (2018). [Mejora de la calidad de la energía con sistemas fotovoltaicos en las zonas rurales](#). *Revista Científica* 33, 3, 265–274.

Article

Rodríguez Padilla, V., y Sheinbaum Pardo, C. (2002). El sistema de precios de la electricidad en México: problemas y soluciones. *Problemas Del Desarrollo. Revista Latinoamericana de Economía* 38(128), 211-231.

Secretaría de Energía. (2022). *Electricidad. Consumo. Secretaría de Energía*. Recuperado el 18 de Junio de 2025 de

Basics

Campos, L. y Quintanilla, J. (1997). *Energía Eléctrica y Medio Ambiente en México*. Instituto de Investigaciones Económicas

enerTIC. (10 de Febrero de 2022). *La importancia de la energía en entornos rurales para fomentar a la digitalización de redes*. Recuperado el 19 de Junio de 2025 de

Zarate, E. (2022). Sociología de energías renovables y transformación energética en México. *Estudios Sociológicos De El Colegio De México*, 41(122), 441–470.

Supports

Arellano, P., y Chapa, J. (2017). Efecto del precio de la electricidad en los hogares mexicanos con perspectiva de género y condición de pobreza. *Análisis Económico*, 22(80), 69-92.

Cruz, Q., y Vargas, A. (2021). *La energía eléctrica y las comunidades rurales de Querétaro*. Archivos. La Lupa, historias que se cuentan. Recuperado el 20 de Junio de 2025.

Dirección General de Comunicación Social (2025). *Debemos transitar hacia un modelo energético que atienda las prioridades de México: Luca Ferrari*. Dirección General de Comunicación Social UNAM.

Expreso Querétaro. (20 de Mayo de 2025). *Paneles solares y nuevo cableado: así busca Querétaro resolver la falta de luz en la Sierra Gorda*.

Grupo Bimbo. (16 de Noviembre de 2023). *Avanzamos hacia las cero emisiones netas de carbono; el 92% de nuestra energía proviene de fuentes renovables*. Prensa: Grupo Bimbo.

Mercado Polo, V., Peña, J. B., y Pacheco, L. (2017). Calidad de la energía eléctrica bajo la perspectiva de los sistemas de puesta a tierra. *Ciencia e Ingeniería*, 38(2), 167-176.

Pesantez, G., Ugsha, N., Guamán, W., Proaño, X., y Casillas, G. (2021). Rendimiento del Sistema Primario de Distribución por interrupciones. *Revista Técnica "energía"*, 1(18), 19-28.

Differences

Microsoft Copilot. (2025, octubre 10). Consulta sobre cooperativas de energías renovables en México [Comunicación personal].

Discussions

Alaminos, J., Alcor, E., Asensio, M., Bernadó, R., Fernández, L., Gómez, E., Iriarte, L., Labriet, M., López, L., Mejicanos, A., & Peiró, J. J. (2013). Estudio sobre las microrredes y su aplicación a proyectos de electrificación de zonas rurales. *Energía Sin Fronteras*.

Ceballos, F., Eastmond, A., Patiño, R., y Sánchez, A. (2022). Comunidades mayas de Yucatán ante un parque eólico: pobreza energética y percepciones de injusticia. *Cronía*, 66-67.

Código Querétaro. (23 de octubre de 2024). *CFE arrancó modernización eléctrica en Jalpan de Serra*. Local: Código Querétaro.

Deutsche Gesellschaft für Internationale Zusammenarbeit. (2020). *Guía de cooperativas de energía sustentable en México*.

Díaz Rodríguez, J., Pabón Fernández., Pardo García, A (2012). Sistema Híbrido de Energía Utilizando Energía Solar y Red Eléctrica. *Lámpsakos (revista Descontinuada)*, 7, 69–77.

Goldwyn, D., & Hernández, C. (11 de Marzo de 2025). *Mexico's new electricity law could boost the country's energy sector. But big questions remain*. Atlantic Council Tv.

Instituto Mexicano para la Competitividad. (19 de Septiembre de 2024). *México ante la saturación de las redes eléctricas*. Centro de Investigación en política pública: IMCO.

Levy, A., y Carrasco, J. J. (2020). *Calidad y confiabilidad de los servicios eléctricos en América Latina*.

Municipio de Jalpan de Serra. (12 de Mayo de 2025). *Gobierno Municipal y CFE revisan acciones clave para mejorar el servicio eléctrico en Jalpan*.

Design and selection of solid urban waste collection routes using mixed integer linear programming under a practical approach

Diseño y selección de rutas de recolección de residuos urbanos sólidos utilizando programación lineal entera mixta bajo un enfoque práctico

Velarde-Cantú, José Manuel^{*a}, López-Acosta, Mauricio^b, Chacara-Montes, Allán^c and Ramírez-Cardenas, Ernesto^d

^a Instituto Tecnológico de Sonora • 0000-0002-1697-8551 • 170193

^b Instituto Tecnológico de Sonora • X-4274-2019 • 0000-0003-3728-9576 • 277997

^c Instituto Tecnológico de Sonora • 0000-0002-0567-0017 • 282326

^d Instituto Tecnológico de Sonora • 0000-0002-5248-724X

Classification:

Area: Physics-Mathematics and Earth Sciences
 Field: Mathematics
 Discipline: Operative investigation
 Subdiscipline: Distribution and transport

<https://doi.org/10.35429/JTD.2025.9.22.6.1.7>

History of the article:

Received: January 13, 2025

Accepted: November 10, 2025

* jose.velarde@itson.edu.mx



Abstract

This research presents the design and selection of solid urban waste collection routes that may or may not be polluting depending on the area of application of the problem addressed, this design uses a mathematical model in mixed integer linear programming, in which the vehicle leaves from a collection center to each collection point located at strategic points of a city, through a fleet of homogeneous vehicles with limited known capacity in which it seeks to minimize the total distance traveled, the time used in collection as well as the reduction in the use of available resources to carry out this activity.

Resumen

En esta investigación se presenta el diseño y selección de rutas de recolección de desechos urbanos sólidos que pueden ser contaminantes o no dependiendo del área de la aplicación del problema abordado, este diseño utiliza un modelo matemático en programación lineal entera mixta, en el cual se el vehículo parte desde un centro de acopio hacia cada punto de recolección ubicados en puntos estratégicos de una ciudad, mediante una flota de vehículos homogénea con capacidad conocida limitada en la que se busca minimizar la distancia total recorrida, el tiempo utilizado en la recolección así como también la reducción en el uso de los recursos disponibles para llevar a cabo esta actividad.

Design and selection of solid urban waste collection routes using mixed integer linear programming under a practical approach		
Objetive	Methodology	Contribution
Design of distribution or collection routes that contribute to the efficient management of available logistics resources.	Use operations research through mixed integer linear programming that provides a solution to the problem addressed	An optimization model in MIPL appropriate to the problem at hand. Optimal design of distribution or collection routes that makes efficient use of available logistics resources.

VRP, MILP, Transport

Diseño y selección de rutas de recolección de residuos urbanos sólidos utilizando programación lineal entera mixta bajo un enfoque práctico		
Objetivo	Metodología	Contribuciones
Diseño de rutas de distribución o recolección que coadyuven al manejo eficiente de los recursos logísticos disponibles.	Utilizar la investigación de operaciones por medio de la programación lineal entera mixta que de solución al problema abordado.	Modelo en MIPL de optimización adecuado al problema abordado. Diseño optimo de rutas de distribución o recolección que eficiente los recursos logísticos disponibles.

VRP, MILP, Transporte

Area: Development of strategic leading-edge technologies and open innovation for social transformation

Citation: Velarde-Cantú, José Manuel, López-Acosta, Mauricio, Chacara-Montes, Allán and Ramírez-Cardenas, Ernesto. [2025]. Design and selection of solid urban waste collection routes using mixed integer linear programming under a practical approach. Journal of Technological Development. 9 [22] 1-7: e60922107



ISSN 2531-2960/© 2009 The Authors. Published by ECORFAN-México, S.C. for its Holding Spain on behalf of Journal of Technological Development. This is an open-access article under the license CC BY-NC-ND license [<http://creativecommons.org/licenses/by-nc-nd/4.0/>]

Peer review under the responsibility of the Scientific Committee MARVID® in the contribution to the scientific, technological and innovation Peer Review Process through the training of Human Resources for the continuity in the Critical Analysis of International Research.



Introduction

In the last decade, economic growth has favored the increase in the country's domestic consumption, thanks to this the emission of solid waste has also been increasing, coming to be considered a problem of vital importance since there are limited resources for its collection Fig. 1. In this type of problems the solution not only depends on the application of various methodologies, tools or knowledge in order to find a route to follow that satisfies the demand for collection of these wastes at minimum cost, it also depends largely on a change of the inhabitants and their governments which must work on a better analysis of the designs of collection systems that allow developing efficient and innovative solutions to this problem.

Within the problem of urban solid waste collection, a wide variety of tasks or activities can be found to be developed, ranging from the location of the containers where each user must deposit their waste, to studies of garbage generation, passing through the definition or calculation of both the fleet size and the personnel necessary to cover the demand, the design of the collection routes to follow, and thus reaching the waste treatment site.

Box 1



Figure 1

Urban solid waste

The general urban solid waste collection system can be divided into three stages. The first identifies the different sources of waste emissions and estimates their quantities. In the second stage, the waste collection system is established, leading to the third and final stage, which is waste treatment or disposal Mula et al. (2010).

The application of new tools and technologies to problems such as vehicle routing has increased in recent years. The goal is to find a solution that provides decision-makers with sufficient information about the different variables that make up the distribution system to ensure efficient use and allocation of available logistics resources.

Within these transportation or collection problems we find the vehicle routing problem (VRP) for its acronym in English, in Elatar et al, (2023) where it describes a series of special and general considerations intrinsic to the VRP among them it is mentioned that this problem belongs to a special type of combinatorial optimization, NP-Hard and that it was referred to for the first time in 1959 by Dantzing, whose primary objective is to design the different optimal distribution and / or collection routes that each of the vehicles must use starting from a distribution center, warehouse or plant and that through the visit scheduling provided by the solution to the problem, carry out the collection and / or delivery activities in order to meet the demand established at each point (client) and then return to the central warehouse (to the starting point), research on this problem has grown very rapidly causing multiple variants of this VRP.

The problem addressed arises from the need for proper management of the use of various resources, including materials, equipment, and human resources available to carry out solid waste collection in a city in the southern region of Sonora, using a mathematical model that contributes to a better allocation of these resources, respecting applicable regulations and standards.

Method Description

Currently, the importance of proper management of solid waste collection has been increasing due to the major health threats and environmental impact this represents. Hence, the need for adequate and efficient procedures for managing this waste that help optimize the use of available resources.

Among the many studies on this problem, one can find Dotoli and Epicoco (2017), who present a technique for solving the collection routing and scheduling problem based on limiting the total distance traveled by road along the route in order to save operating costs and particulate pollutant emissions into the environment, considering service times, vehicle availability, and time windows.

In the literature, multiple techniques can be found to find solutions to the problem addressed. One of them is proposed by Hnaïen et al (2016), who uses a mixed-integer linear programming (MILP) mathematical model whose objective is to minimize the sum of the total costs. Likewise, Kechmane (2015) used a mathematical model with the objective of minimizing total transportation costs, also seeking to optimize the allocation of vehicles to trips, thus reducing the distances traveled. This work considers the capacity restrictions of each vehicle and each distribution center, as well as the fulfillment of the demand in each client.

Having efficient collection routes can help reduce operating costs and environmental emissions by reducing the route travel distance. It is critical to apply new technologies and optimization techniques to this problem, such as the one proposed by Akhtar et al (2017). He presents a modified search algorithm for the capacitated vehicle routing problem (CVRP). This algorithm uses the concept of a smart container to find the best waste collection route. This smart container provides a signal of the waste level it has, sending this signal to a center, which then maps the collection route to only those containers that need to be emptied, finding an optimal range, thus minimizing the distance traveled.

Other authors such as Hassan Sayed et al (2018) propose in their study the use of two different models, the first designed to minimize the installations of the containers and the second to maximize the coverage by seeking to find the optimal locations of these collection centers, in their study they consider four main or effective factors, including the total coverage of the service, the residential commitment, the capacity of the containers in each location and the relationship between the standard deviation and the arithmetic mean of the volume of solid waste in each station.

The results obtained from the comparison of these two methods demonstrated the levels of service offered, the second one being the one that showed the best performance, managing to obtain locations of the containers between 0 to 100 meters away from the end users.

In Guerrini Andrea et al. (2017), a nonparametric method was established to solve the solid waste collection problem. This method is based on calculating the system's performance to identify the environmental and operational variables that affect the efficiency and quality of the services provided.

This method used variables related to customer characteristics (population size by area, population density, tourist flow), those related to housing characteristics (house measurements per inhabitant per house), and operational characteristics such as waste collected in tons per route or per trip. They found that all the variables involved affect efficiency to varying degrees and directions, and therefore also the cost of collection.

The problem of designing collection routes for vehicles with capacity constraints is considered in the literature to be difficult to solve due to the multiple combinations that can exist, making it difficult to find a solution that satisfies all the optimality conditions of the problem.

In Veer et al, (2023) one can observe the implementation of a metaheuristics based on a Tabu search to face this problem where a collection route must be built and selected using vehicles with defined and limited capacity without time limitations, the results obtained with the application of this algorithm surpass other techniques with instance sizes considered as large, but for small instance sizes, the local search with the TABU search produces results comparable to exact optimization in a shorter period of time, in this way the idea of applying exact and/or heuristic algorithms for medium to small sized problems in the exploration of optimal solutions is fortified.

Among the numerous variants of the Vehicle Routing Problem (VRP), we can identify applications where the route in a network consists of a different origin than the final point or destination.

The solution to this type of problem can be obtained using shortest path algorithms between points, etc. VRPs are typically an exact description of many multi-company distribution systems, where delivery or collection situations are the core of their service. For example, garbage collection, personnel transportation, and school transportation systems can be modeled in a similar way due to their similar characteristics.

Based on the state-of-the-art review, the decision was made to use an exact solution method, which is based on the modification and adaptation of a mathematical model proposed by Akhtar Mahmuda et al. (2017) for the vehicle routing problem. Likewise, AMPL software was used with the CPLEX version 12.7 optimizer. The use of an exact solution technique can be considered risky since the computational time for large problems is usually very long. For the practical case addressed, this was not a problem since the problem size was considered small, as the application was to a pilot test group, which guarantees that we can find the optimal solution in a reasonably short time.

The following section shows the mathematical model based on mixed integer linear programming (MILP), which was proposed taking into account the different characteristics of the real-world problem of route design for the vehicle routing problem.

Mathematical Model

Model Assumptions

The following conditions are considered so that the model adequately represents the real-world problem:

- All vehicles depart from and return to the final depot.
- All vehicles start their journeys from the depot at the same time.
- Each waste container is visited by only one vehicle.
- The cumulative waste capacity of all containers on a route must not exceed the maximum vehicle capacity.
- The vehicle fleet and waste containers are homogeneous.

Indexes and Parameters:

V : Total number of container locations to be collected. $n \in |V|$.

N : Total number of container locations to be collected including the final deposit $N \cup V$.

K : Total number of vehicles available $k \in |K|$.

C_k : Vehicle capacity $k, k \in K$

i, j : indexes corresponding to the location of containers $i, j, i, j \in |V|$

L_{ij} : Distance between the location of container i and container j .

Q_{ij}^k : Vehicle load k between container locations i, j .

Decision Variables of the Model

$$X_{ij}^k = \begin{cases} 1, & \text{If the vehicle visits the container} \\ & \text{locations } ij. \\ 0, & \text{in any other case.} \end{cases}$$

$$W_{ij} = \begin{cases} 1, & \text{if the location of the container } i \\ & \text{belongs to the vehicle's route } k. \\ 0, & \text{in any other case.} \end{cases}$$

Objective Function

$$F.O \text{ Min } Z = \sum_{i=0}^n \sum_{j=0}^n \sum_{k=1}^K L_{ij} X_{ij}^k \quad [1]$$

Sujeto a:

$$\sum_{j=1}^n \sum_{k=1}^K X_{0jk} = 1 \quad [2]$$

$$\sum_{j=1}^n Q_{0jk} = 1 \quad \forall k = \{1, 2, \dots, K\} \quad [3]$$

$$\sum_{j=1}^n \sum_{k=1}^K X_{ij}^k = 1 \quad \forall j = \{1, 2, \dots, n\} \quad [4]$$

$$\sum_{j=1}^n X_{ij}^k - \sum_{j=1}^n X_{ji}^k = W_{ik} \quad \forall i = \{1, 2, \dots, n\}, \\ k = \{1, 2, \dots, K\} \quad [5]$$

$$\sum_{i=0}^n \sum_{h=1}^K Q_{ji}^k - \sum_{i=0}^n \sum_{k=1}^K Q_{ij}^k = C_j, \quad \forall j = \{1, 2, \dots, n\}, \quad [6]$$

$$\sum_{j=1}^n C_i X_{ij}^n \leq C_k, \quad \forall j = \{1, 2, \dots, n\}, \quad k = \{1, 2, \dots, K\} \quad [7]$$

$$\sum_{i=1}^n \sum_{j=1}^n X_{i0}^k = 1 \quad [8]$$

The equation (1) represents the objective function which seeks to minimize the total sum of the distances traveled by the vehicle on each route. The equations (2) and (3) specify that each vehicle k must start the trip from the depot without cargo. According to equation (4), each location of each container is visited by only one vehicle. The equation (5) ensures the continuity condition, that is, if vehicle k enters a location, it must also leave that location. The equation (6) ensures that every vehicle must empty the contents of the containers visited. The equation (7) ensures that the maximum capacity of the vehicle is not exceeded by stating that this capacity must be less than or equal to the total waste collected from all containers visited on the trip. Finally, the equation (8) ensures that each vehicle must return to the depot after the trip.

Results:

The presented work considers the vehicle routing problem applied to the urban solid waste collection problem in a given area. For this purpose, the work presented by Akhtar Mahmuda et al. (2017) was used as a reference. This work considers waste collection using vehicles with homogeneous capacities. This work was modified to adapt to the real-world problem addressed, which considers different capacities for various types of vehicles. The results obtained establish the different values of the decision variables, as well as compliance with the different constraints that together define the optimal solution to the problem addressed.

For the practical problem, a set of nine container locations in a defined area were considered. Table 1 shows the different distances between the collection locations, where M represents a very large value.

The objective is to minimize the total distance traveled by the vehicle while considering compliance with the set of model constraints.

Box 2

Table 1

Table of distances of container locations in kilometers

	1	2	3	4	5	6	7	8	9
1	M	2.2	2.5	3.8	2.5	3	4.1	1	34.4
2	2.2	M	1.6	1.4	2.4	3	4.1	2.4	37.8
3	2.5	1.6	M	1.3	1	1.6	2.6	2.2	38.7
4	3.8	1.4	1.3	M	1.7	2.2	3.2	2.9	37.5
5	2.5	2.4	1	1.7	M	0.6	1.8	2	36.1
6	3	3	1.6	2.2	0.6	M	2.1	2	35.9
7	4.1	4.1	2.6	3.2	1.8	2.1	M	4.4	37.4
8	1	2.4	2.2	2.9	2	2	4.4	M	37.8
9	34.4	37.8	38.7	37.5	36.1	35.9	37.4	37.8	M

The results obtained with the implementation of AMPL software with the CPLEX optimizer version 12.10 are presented below, obtaining very favorable results in the search for minimizing the collection and transportation costs included in the trips of each vehicle used. Table 2 shows the route designed for these vehicles, which meets the requirements agreed with the client. A comparison is also presented with a heuristic method in which a genetic algorithm was applied, finding the following results (see Table 2).

Box 3

Table 2

Results of both solution methods

Method Used	Selected Route	Traveled Distance (Kilometers)
Exact Method	1-8-2-4-3-5-7-6-9-1	81.3
Heuristic Algorithm	1-9-6-7-5-3-4-2-8-1	81.3

The results show that both methods give us the same total distance traveled for the pilot case, which guarantees that the alternative (heuristic) method of using a genetic algorithm provides a solution that is equally good as the exact method. It can be seen that the solutions reported in terms of the collection route are the same, with only a small difference: they are reported in reverse regarding the start and end order of each route.

The implementation of the genetic algorithm programmed in Microsoft Excel software was sought because an economical option was sought that the company could access without a large investment, which is why it was decided to use this tool.

Velarde-Cantú, José Manuel, López-Acosta, Mauricio, Chacara-Montes, Allán and Ramírez-Cardenas, Ernesto. [2025]. Design and selection of solid urban waste collection routes using mixed integer linear programming under a practical approach. Journal of Technological Development. 9 [22] 1-7: e60922107

<https://doi.org/10.35429/JTD.2025.9.22.6.1.7>

Conclusions

The application of exact optimization techniques to the problem of solid waste collection in a network represented for the company a better use of the resources available for the design of collection routes, due to the establishment of a collection route that minimizes travel time while respecting the characteristics of the practical problem addressed. The results helped the company establish a methodology that systematically solves the problem of collection route design. In the same way, it demonstrated that optimization techniques can represent an interesting option to address small to medium-sized problems, offering results that can increase the efficiency of its different distribution logistics systems, allowing the company to minimize operating costs and increase its profitability.

Recommendations

Consideration should be given to expanding the scope of the research by considering different areas where collection routes should be carried out, as well as having trained human resources that can efficiently operate the methodology in case adjustments need to be made or to adequately interpret the solution. Likewise, it is of utmost importance to consider establishing controls that help better monitor the implementation and start-up of the solution to ensure that the results are as expected by the company.

Declarations

Conflict of interest

The authors declare no interest conflict. They have no known competing financial interests or personal relationships that could have appeared to influence the article reported in this article.

Author Contributions

Conceptualization, J.V., M.L.; methodology, J.V., A.C.; software, J.V., A.C.; resources, J.V., M.L. E.R.; writing—original draft, J.V., A.C., M.L., E.R.; writing—review and editing, J.V., M.L., A.C., E.R.; visualization, J.V.; project administration, J.V., M.L.; funding acquisition, J.V., M.L., A.C. All authors have read and agreed to the published version of the manuscript.

Availability of data and materials

The data presented in this study are available on request from the corresponding authors

Funding

This work was supported by the Technological Institute of Sonora (ITSON), Mexico through the Research Promotion and Support Program (PROFAPI 2025).

Acknowledgements

On behalf of the team, we would like to thank all the participants for their interest and collaboration during the data collection used in this research. We also thank the university (Sonora Institute of Technology), the 2025 Research Project Promotion and Support Program (PROFAPI 2025), and the company for their support and assistance in developing the project.

Abbreviations

AMPL	A Modeling Language for Mathematical Problems
CVRP	Capacited Vehicle Routing Problem
MIPL	Mixed Integer Linear Programming
VRP	Vehicle Routing Problem

References

Antecedents

Hnaïen F., Yalaoui F., Mhadhbi A., and Nourelfath M., [A mixed-integer programming model for integrated production and maintenance](#), IFAC PapersOnLine, Volume 49, Issue 12, Pág. 556-561, (2016).

Kechmane L, Nsiri B, and Baalal A., [A Mathematical Model to Optimize Transport Cost and Inventory Level in a Single Level Logistic Network](#), Computational Problems in Science and Engineering, Vol. 343, Pág. 271-281, 2015.

Mula, J., Peidro, D., Diaz-Madronero, M., Vicens, E., [Mathematical programming models for supply chain production and transport planning](#), European Journal of Operational Research, Vol. 204 (3), Pág.377-390, 2010.

Basics

Akhtar M., Hannan M., Begum R., Hassan B., y Scavino E., [Backtracking search algorithm in CVRP models for efficient solid waste collection and route optimization](#). Waste Management (2017).

Dotoli M. y Epicoco N., [A Vehicle Routing Technique for Hazardous Waste Collection](#), International Federation of Automatic Control Hosting by Elsevier, ScienceDirect, Vol. 50 No. 1 Pág. 9694–9699, (2017)

Guerrini A., Carvalho P., Romano G., Cunha Marques R., y Leardini C., [Assessing efficiency drivers in municipal solid waste collection services through a non-parametric method.](#), Journal of Cleaner Production Vol. 147, Pág. 431 a 441, (2017).

Supports



Veer K., Kumar S., [An optimization model for vehicle routing problem in last-mile delivery](#), Elsevier, Expert Systems With Applications Vol. 222. Pág. 1-15, 2023.



Elatar S., Abouelmehdi K., Essaid M. [The vehicle routing problem in the last decade: variants, taxonomy and metaheuristics](#), Elsevier, Procedia Computer Science. Vol 220. Pág. 398–404, 2023.



Design and CAD modeling of the mechanical base of an anthropomorphic robot arm, integrating technical analysis, 2D/3D drawing, assembly and animation, for educational purposes

Diseño y modelado CAD de la base mecánica de un robot industrial tipo brazo antropomórfico, integrando análisis técnico, dibujo 2D/3D, ensamblaje y animación, con fines educativos

Peña-Montes De Oca^a, Adriana Isela, Gallardo-De La Rocha, Alfonso^b and Hernández, Adriana Janette^c

^a  Universidad Tecnológica de Jalisco •  0000-0001-8220-3108 •  70757

^b  Universidad Tecnológica de Jalisco •  2051352

^c  Universidad Tecnológica de Jalisco •  000-0001-7102-6062 •  1035189

Classification:

Area: Humanities and Behavioral Sciences

Field: Pedagogy

Discipline: Other pedagogical specialties

Subdiscipline: Other

 <https://doi.org/10.35429/JTD.2025.9.22.7.1.8>

History of the article:

Received: June 13, 2025

Accepted: November 10, 2025

*  [\[adriana-isela@utj.edu.mx\]](mailto:adriana-isela@utj.edu.mx)



Abstract

The objective of this work was to enable eighth-quarter students to develop the design and modeling of the mechanical base for anthropomorphic arm-type industrial robot, integrating technical analysis, 2D/3D drawing, assembly, and animation using CAD software, with a focus on functionality, precision, and educational applicability. The resulting matrix of components that can be integrated for subsequent analysis is presented as follows: Generated Parts, Understanding of manufacturer's drawings, and proper assembly of parts. Functional tests were performed. It was demonstrated that the development of experiences in the area of robotics has allowed participating students to improve their problem-solving skills through virtual models, visualizing their designs in three dimensions and identifying potential problems. Adjustments can save time and resources, and are proposed as future lines of research. As future lines of research, we propose evaluating various forms of work that involve the convergence of digital technologies and hardware to improve processes, simulate multidimensional physical models, and reduce costs. It is worth mentioning that this study is not without limitations, derived from the selection of analyses, therefore, it should be treated with caution.

Resumen

El objetivo del presente trabajo fue lograr que los estudiantes del 8° cuatrimestre, desarrollen el diseño y modelado de la base mecánica para un robot industrial de tipo brazo antropomórfico, integrando análisis técnico, dibujo 2D/3D, ensamblaje y animación, mediante software CAD, con un enfoque en la funcionalidad, precisión y aplicabilidad educativa. Como resultado se obtuvo se presenta la matriz de componentes que se pueden integrar para posteriores análisis como sigue: Piezas Generadas, Comprensión de planos del fabricante y ensamble de piezas correctamente y se realizaron las pruebas de funcionamiento. Se logró evidenciar que los desarrollos de experiencias en el área de robótica han permitido que los estudiantes participantes, mejoren su habilidad de resolución de problemas a través de modelos virtuales, visualizando sus diseños en tres dimensiones e identificando problemas potenciales, que, realizando ajustes, promueven el ahorro de tiempo y recursos. Como líneas de investigación futuras se propone evaluar diversas formas de trabajo que impliquen la convergencia entre las tecnologías digitales y el hardware, a fin de mejorar los procesos; simulando modelos físicos multidimensionales y reducir costos; cabe mencionar que el presente estudio no está exento de limitaciones, derivados de la selección de análisis, por tanto, debe ser tratado con precaución.

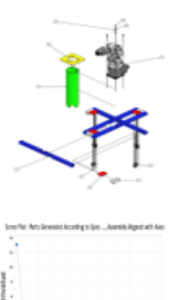
Design and CAD modeling of the mechanical base of an anthropomorphic robot arm, integrating technical analysis, 2D/3D drawing, assembly and animation, for educational purposes		
Objective	Methodology	Contributions
The objective of this Project is to enable eighth-quarter students to develop the design and modeling of the mechanical base for an anthropomorphic arm-type industrial robot, integrating technical analysis, 2D/3D drawing, assembly, and animation using CAD software. The focus is on functionality, precision and educational applicability.		

CAD Design and Modeling, Educational Robotics, Mechatronics

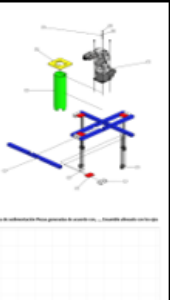
Diseño y modelado CAD de la base mecánica de un robot industrial tipo brazo antropomórfico, integrando análisis técnico, dibujo 2D/3D, ensamblaje y animación con fines educativos		
Objetivo	Metodología	Contribuciones
El objetivo del presente, es lograr que los estudiantes de 8º cuatrimestre, desarrollen el diseño y modelado de la base mecánica para un robot industrial tipo brazo antropomórfico, integrando análisis técnico, dibujo 2D/3D, ensamblaje y animación, mediante software CAD, con un enfoque en la funcionalidad, precisión y aplicabilidad educativa		

Diseño y modelado CAD, Robótica Educativa, Mecatrónica

Area: Development of strategic leading-edge technologies and open innovation for social transformation

Citation: Peña-Montes De Oca, Adriana Isela, Gallardo-De La Rocha, Alfonso and Hernández, Adriana Janette. [2025]. Design and CAD modeling of the mechanical base of an anthropomorphic robot arm, integrating technical analysis, 2D/3D drawing, assembly and animation, for educational purposes. Journal of Technological Development. 9 [22] 1-8: e70922108



ISSN 2531-2960/© 2009 The Authors. Published by ECORFAN-México, S.C. for its Holding Spain on behalf of Journal of Technological Development. This is an open-access article under the license CC BY-NC-ND license [<http://creativecommons.org/licenses/by-nc-nd/4.0/>]

Peer review under the responsibility of the Scientific Committee MARVID® in the contribution to the scientific, technological and innovation Peer Review Process through the training of Human Resources for the continuity in the Critical Analysis of International Research.



Introduction

In the early 1990s, the concept of parametric design gained momentum, where product modeling was performed under certain geometric criteria that allowed different configurations by changing the values of some parameters. Several companies adopted this work concept and have now consolidated their position with the incorporation of associative technologies (Bodein y col., 2014)

The tools for Computer Aided Design (CAD) is constantly evolving and most branches of technology use it to increase the productivity of designers and to obtain more complex and precise elaborations every day.

In recent years CAD software, some of which is offered as a free or open source Project, has been a key conditions for the expansion of 3D modeling and rapid prototyping.

A designer working on a system with a high-resolution screen generates various views of components and assemblies, he can also obtain three-dimensional views that can be zoomed, rotated and cut into sections, allowing customers and profesionales involved in design and manufacturing to form an idea of the product in question, facilitating all possible modifications and defect elimination before the product goes to market.

Initially CAD was introduced to assist designers in error-proofing their designs. It was also used to aid engineering analysis. Although the design process continued to be performed by hand for a long time, at certain points throughout these processes, data was entered into computer programs that analyzed and identified potential errors, and then made the necessary modifications to these designs (Fakhry y col., 2021).

In addition, it allows you to include standardized elements in your Project, verify interactions with mechanical construction parts, and optimize the creation of shop drawings and safety factors, as well as analyze movement trajectories (Mercado-Bautista, 2020). A significant advantage lies in the analysis and optimization of designs, as it allows for increased product efficiency and error elimination without generating additional costs for real prototypes (Lopes and Guedes, 2016)

The objective of this Project is to enable eighth-quarter students to develop the design and modeling of the mechanical base for an anthropomorphic arm-type industrial robot, integrating technical analysis, 2D/3D drawing, assembly, and animation using CAD software. The focus is on functionality, precision and educational applicability. This approach develops skills such as creativity and critical thinking to enhance their problem-solving abilities (Diago, Arnau and González-Calero, 2018; Benitti, 2012).

The first section presents a literature review, conceptual framework, and methodology, as well as a review of the work related to the design of the mechanical base for an anthropomorphic arm-type industrial robot.

The second section describes the methodology used, followed by sections on analysis of results, discussion, conclusions and limitations, as well as proposals for future research work.

Contextual Framework

From a practical perspective, robots are machines that function by emulating human processes. The robot design process generally requires a balance between functionality structure, and aesthetics, as well as other associated interests (Yang and col., 2022.)

Robots can be classified by configuration as a) Cartesian, b) Cylindrical, c) Spherical, d) Angular, e) SCARA and f) Parallel (Barrientos y col., 2007). Articulated robots have an arm composed of three rigid members connected by two rotating joints. The arm is mounted on a rotating base. Thus, engineers prioritize functional characteristics, that is, they are responsible for formulating the technical specifications that govern the manufacturing process, product performance, and its overall shape.

To extend the lifespan of robots and facilitate their maintainability, the implementation of a mechanical base that improves stability, strength, and precision has become popular; allowing a wide range of movements and/or more complex movements, allowing the robot to perform different tasks, in addition to providing support and locomotion capabilities to interact with different environments or increasing energy efficiency.

Peña-Montes De Oca, Adriana Isela, Gallardo-De La Rocha, Alfonso and Hernández, Adriana Janette. [2025]. Design and CAD modeling of the mechanical base of an anthropomorphic robot arm, integrating technical analysis, 2D/3D drawing, assembly and animation, for educational purposes. Journal of Technological Development. 9 [22] 1-8: e70922108
<https://doi.org/10.35429/JTD.2025.9.22.7.1.8>

Mechanical bases can be fixed or mobile

Depending on the movement method, mobile robots fall into two main categories: wheeled robots and legged robots. Legged robots are classified according to the number of legs they use for movement and the degrees of freedom of each one. Therefore, perhaps the most valuable characteristic of an articulated robot is its mechanical flexibility.

The design and construction of experimental prototypes with creativity and originality, involving a problem-solving process to develop skills in the use of structural, mechanical, and spatial geometric patterns (Diago, Arnau and González-Calero, 2018; González-Calero, Cózar, Merino and Villena, 2018; Martínez, Escamilla and Campos, 2019; Niño and Fernández, 2019; Restrepo y col., 2022).

Methodology

Project management involves the application of knowledge, skill, tools and techniques and It is constituted by the following stages:

– Project Planning

Considering the technical specifications of selected anthropomorphic arm-type industrial robot as a starting point, the necessary parameters for the production of the parts were identified, as well as the standards and measurements for the material available in Mexico.

– Project Management

The mechanical drawings from the robot manufacturer were interpreted, applying knowledge, skills, technical tools, and software (Jiménez Castro and Cerdas González, 2014).

The file type was selected according to the creation needs (element; sheet, solid part, assembly, drawing or animation), following the applicable standards and measurement systems.

– Manufacturing and Assembly Testing

To orient the part, the drawing is selected for the generation of the 2D drawing, followed by the identification of the geometric figure.

In the next step, to represent the shape, the drawn figure is defined, dimensioned, and/or constrained to give volumen and covert it into a 3D figure, using extrusion or swirling.

The process described above for making the parts needed to build an assembly is multiplied, inserting each part according to a defined plan, observing restrictions to define the position, orientation, and movement of the parts, until the process is complete and the file is saved.

Once the assembly is complete, check for interferences between parts (over-positioning of one or more parts), and review measurements according to the planned design.

Next, generate the animation file, explode the assembly using the animation file, moving one part or a group of parts to positions where the animation will be located.

It is time to create a list of components needed to manufacture the system or the designed parts, documenting at a minimum: component name, part number, number of parts, and a brief description. Each part and/or component varies in function depending on the assigned configuration. Thus they must fit perfectly according to the intended mechanical design, in order to achieve a consistent and robust model (see Figure 1).

Box 1

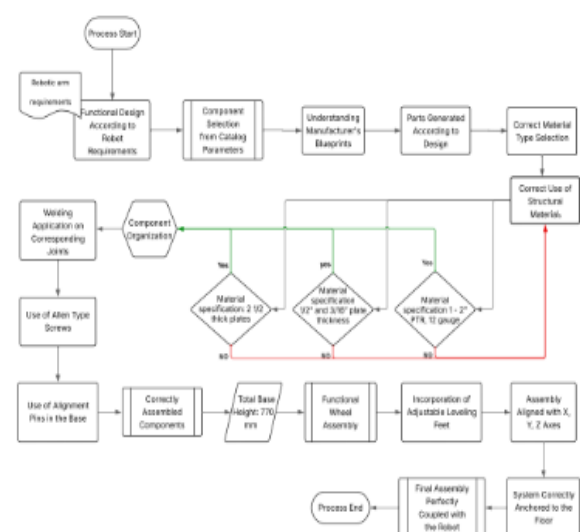

Figure 1

Flowchart for the CAD design of a mechanical base for an anthropomorphic industrial robot.

– Evaluation

Using a checklist (see Table 1) with indicators that allow assessing aspect such as form representation and dimensional an functional compliance.

Box 2

Table 1

List of variables or factors

Variables o Factors	
1	Parts generated according to the design
2	Understanding of manufacturer's drawings
3	Proper assembly of parts
4	Functional wheel assembly
5	Organization of parts
6	Use of parts selected based on catalog parameters
7	Functional design according to robot requirements
8	Total base height: 770 mm
9	Correct use of 2" gauge 12 PTR
10	Use of 1/2" thick plates
11	Use of 2"x2" angle, 5/16" thickness
12	Use of 3/16" thick plate
13	Correct material type selection for each part
14	Final assembly perfectly coupled with the robot
15	Use of Allen-type bolts in connections
16	Welding applied in corresponding joints
17	Use of alignment pins on the base
18	System properly anchored to the floor
19	Incorporation of adjustable leveling feet
20	Assembly aligned with the X, Y, Z plans

It proposed an exploratory studies (Sampieri y col., 2014), it was decided to use a factorial design, as it allows the study of the effect of multiple independent variables (factors) on a dependent variable, followed by a principal components analysis with standardized data to help reduce the dimensionality of the data, identifying the relationships between variables and extracting principal components that explain most of the variance (Martens y col., 2012).

Results

– Project Management

The list of components and requirements necessary for the development of the mechanical base of an anthropomorphic arm-type industrial robot is shown (see Table 2).

Box 2

Table 2

List of components

ITEM	QUANTITY	PART NUMBER / DESCRIPTION
1	4	PTR 2in - 117mm
2	4	Plate 14in - 85mm
3	4	HT515FRHTGA1 Wheel 2in - 67mm
4	1	Post 6in
5	4	PTR 2in - 1000mm
6	1	Plate 12in - 190mm
7	1	KR3 R540
8	16	JIS B 1174 - M5 x 12
9	4	ISO 7089 - 8
10	4	NF E 25-515 - W8
11	4	AS 1420 - 1973 - M8 x 40

Note: The use of a hybrid system of units (in and mm) is required, given the conditions of raw material supply in Mexico.

– Manufacturing and Assembly Testing

Project structure, mechanical modeling and incorporation of part and/or components, taking into account their specific appropriate characteristics and meeting the proposed structural plans.

Below are different angles of the mechanical base of an anthropomorphic arm-type industrial robot (see Figure 2, 3, and 4)

Box 3

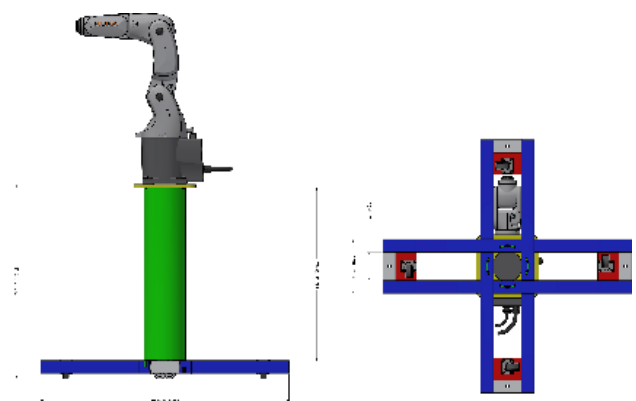

Figure 2

Overview of the robot base

Box 4

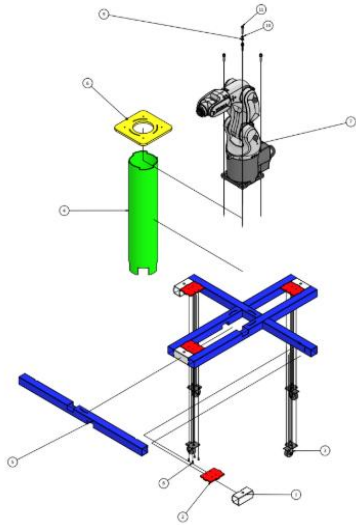

Figure 3
Dismantled or exploited

The exploded view is a type of technical drawing, useful in the assembly of materials and is created by combining assembly files.

Box 5

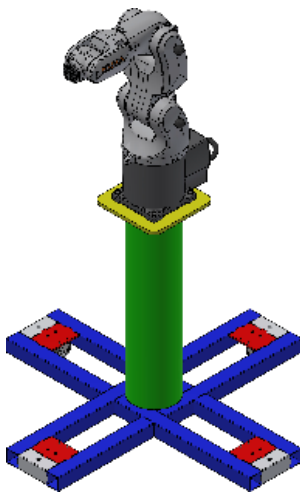

Figure 4
Isometric

Tree-dimensional simulation o visual representation of an object to facilitate understanding of its shape and dimensions. Due to the group conditions, the simple size used was 22 participants. A 95% confidence level was established, and statistical analysis was performed using Minitab 20 software. Although the simple size may seem insufficient to detect small differences, it is considered adequate to explore the relationship between the main variables. The analysis began with Pearson pairwise correlation test, and the most strongly correlated criteria were identified (see Table 3).

Box 6

Pearson Pairwise Correlations

Sample 1	Sample 2	N	Correlation	95% CI for Correlation	p-value
Manufacturer's drawing comprehension	Parts generated according to the	22	0.964	(0.914, 0.985)	0.000
Correct part assembly	Parts generated according to the	22	0.567	(0.190, 0.798)	0.006
Functional wheel assembly	Parts generated according to the	22	0.567	(0.190, 0.798)	0.006
Part organization	Parts generated according to the	22	1.000	(*,*)	*
Use of parts taken from inventory	Parts generated according to the	22	0.869	(0.707, 0.945)	0.000
Functional design per requirements	Parts generated according to the	22	0.690	(0.379, 0.861)	0.000
Total base height: 770 mm	Parts generated according to the	22	0.567	(0.190, 0.798)	0.006
Proper use of 2" PTR calibration	Parts generated according to the	22	0.869	(0.707, 0.945)	0.000
Use of parts with 1" thickness	Parts generated according to the	22	1.000	(*,*)	*
Use of 2"x1" angle with 5" thickness	Parts generated according to the	22	0.516	(0.121, 0.770)	0.014
Use of parts with 3/16" thickness	Parts generated according to the	22	1.000	(*,*)	*

Table 3
Fraction of Pearson pairwise correlations

As an example, stongly correlated criteria include: Final Assembly Perfectly Coupled with the Robot and Functional Design According to Robot Requirements. Other important relationships include assembly aligned with the XY, XZ, and YZ planes, and correct asblmy of parts.

Box 7

Strongly Correlated

Correctly anchored system	Correctly assembled parts	22	0.726	(0.438, 0.879)	0.000
Incorporation of leveling feet	Correctly assembled parts	22	0.528	(0.137, 0.777)	0.011
Assembly aligned with the plans	Correctly assembled parts	22	0.736	(0.456, 0.883)	0.000

Table 4
Correlations

After confirming importan correlations, a standardization was applied in order to test a Factor Analysis followed by the Principal Components Test, it was tested with 5 strongly related factors, obtaining that the parts generated according to the robot design explain 98.7% of the variability, fulfilling the purpose of defining the structure of interrelations (see Table 5).

Box 8

Table 5

Tested with five strongly related factors

Unrotated Factor Loadings and Communalities

Variable	Factor1	Factor2	Factor3	Factor4	Factor5	Communality
Parts generated according to spec_1	0.957	-0.238	0.063	0.067	0.083	0.987
Fabrication timeline compressor_1	0.92	-0.306	0.119	0.093	0.052	0.965
Corrective part assemblies_1	0.768	0.374	-0.087	-0.201	-0.016	0.916
Mid-functional assembly_1	0.572	-0.104	0.441	-0.552	-0.099	0.847
Part organization_1	0.957	-0.238	0.063	0.067	0.083	0.987
Use of parts sourced from inventory_1	0.886	-0.182	-0.366	-0.102	-0.03	0.981
Functional design per requirements_1	0.82	0.475	0.175	0.178	-0.041	0.961
Total base height_1	0.74	0.481	-0.188	0.142	-0.297	0.922
Proper use of PTR_7 calibration_1	0.811	-0.299	0.038	0.118	0.213	0.808
Use of plates with specified material_1	0.957	-0.238	0.063	0.067	0.083	0.987
Use of 2"x2" angle with correct thickness_1	0.492	-0.338	0.298	0.222	-0.671	0.945
Use of 3/16" plates with specified material	0.957	-0.238	0.063	0.067	0.083	0.987
Correct fastener type selection_1	0.896	-0.185	-0.366	-0.102	-0.03	0.981
Perfectly coupled final assembly_1	0.835	0.299	0.08	0.295	0.219	0.928
Use of type A1 fasteners_1	0.7	0.146	-0.488	0.134	0.038	0.769
Proper welding application_1	0.694	0.49	0.174	0.293	-0.05	0.84
Use of aligned handles_1	0.703	0.487	0.194	-0.023	0.186	0.804
Correctly anchored system_1	0.654	-0.304	-0.061	-0.575	0.01	0.844
Incorporation of leveling feet_1	0.754	-0.28	0.273	0.155	0.144	0.767
Assembly aligned with reference axes_1	0.866	0.026	-0.242	-0.205	-0.291	0.936
Metric						
Explained Variance	13.045	2.092	1.107	1.098	0.821	18.163
% of Total Variance	0.652	0.105	0.055	0.052	0.041	0.908

Subsequently, factors were eliminated, to use only the three main strongly related factors and the explanation of 97.5 % of the relationships was obtained (see Table 6).

Box 9

Table 6

Tested with three strongly related factors

Unrotated Factor Loadings and Communalities

Variable (English Translation)	Factor1	Factor2	Factor3	Communality
Parts generated according to spec_1	0.957	-0.238	0.063	0.975
Drawing compensation in fab_1	0.92	-0.306	0.119	0.954
Correct part assembly_1	0.768	0.525	-0.087	0.873
Functional wheel assembly_1	0.572	-0.104	0.441	0.533
Part organization_1	0.957	-0.238	0.063	0.975
Use of parts taken from inventory_1	0.896	-0.182	-0.366	0.97
Functional design per requirements_1	0.82	0.475	0.175	0.928
Total base height: 770_1	0.74	0.481	-0.188	0.814
Correct use of 2" PTR calibration_1	0.811	-0.299	0.038	0.749
Use of plate with thickness_1	0.957	-0.238	0.063	0.975
Use of 2"x2" angle with thickness_1	0.492	-0.338	0.298	0.445
Use of 3/16" thick plate_1	0.957	-0.238	0.063	0.975
Correct fastener type selection_1	0.896	-0.182	-0.366	0.97
Perfectly coupled final assembly_1	0.835	0.299	0.08	0.792
Use of type A1 fasteners_1	0.7	-0.146	-0.488	0.75
Welding application_1	0.694	0.49	0.174	0.752
Use of alignment pins_1	0.703	0.487	0.194	0.769
Correctly anchored system_1	0.645	0.304	-0.061	0.513
Incorporation of leveling feet_1	0.754	-0.28	0.273	0.722
Assembly aligned with reference axes_1	0.866	0.026	-0.242	0.809
Metric				
Explained Variance	13.045	2.092	1.107	16.244
% of Total Variance	65.20%	10.50%	5.50%	81.20%

The graph shows three strongly related factors (see Figure 5).

Box 10

Scree Plot Parts Generated According to Spec ..., Assembly Aligned with Axes

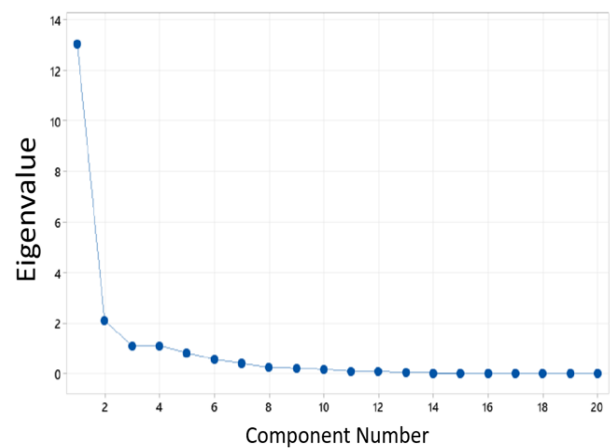

Figure 5

Scree chart showing three main factors

Finally, the matrix of components that can be integrated for further analysis is presented:

Generated Parts, Understanding of Manufacturer drawings and Correct Assembly of Parts.

Conclusions

Data analysis began with the confirmation of significant correlations. Standardization was applied to test a Factor Analysis followed by the Principal Components test. The matrix of components that can be integrated for subsequent analysis was obtained: Generated Parts, Understanding of Manufacturer's Drawings, and Part Assembly Correctly, as they explain 97.5% of variability.

Any branch of industry, science or technology can benefit from computer-aided design, analysis, and manufacturing, increasing the quality, precision, and productivity of almost any item or activity, thereby improving the quality of life for humans.

As future lines of research, we propose evaluating various ways of working that involve the convergence of digital technologies and hardware to improve processes, simulate multidimensional physical models, and reduce costs (Pérez, Niño y Fernández, 2020). It should be noted that this study is not without limitations derived from the selection of analyses; therefore, it should be treated with caution.

Availability of data and materials

The authors may make unshared data used to generate the results reported in the article available to interested parties upon request.

Funding

Own resources in the academic secretary dedicated to research.

Acknowledgements

Thank Dr. Héctor Pulido González, Rector de la Universidad Tecnológica de Jalisco, for providing the necessary means to carry out this Project.

References

Barrientos A., Penin L.F., Balaguer C. Aracil R., (2007) *Fundamentos de Robótica*, Ed. 2a. España: McGraw Hill.

Benitti, F. B. V. (2012). *Exploring the educational potential of robotics in schools: A systematic review*. *Computers & Education*, 58(3), 978-988.
<https://doi.org/10.1016/j.compedu.2011.10.006>

Bodein, Y., Rose, B., y Caillaud, R., (2014) *Explicit reference modeling methodology in parametric CAD system*.
<https://doi.org/10.1016/j.compind.2013.08.004>, *Computer In Industry*, 65(1), 136-147

Diago, P., Arnau, D. y González-Calero, J. A. (2018). *Elementos de resolución de problemas en primeras edades escolares con Bee-bot*. Edma 0-6: Educación Matemática en la Infancia, 7(1), 12-41.

Fakhry, M., Kamel, I., y Abdelaal, A., (2021) *CAD using preference compared to hand drafting in architectural working drawings coursework*.
<https://doi.org/10.1016/j.asej.2021.01.016>, *Ain Shams Engineering Journal*, 12(3), 3331-338

González-Calero, J. A., Cózar, R., Villena, R., & Merino, J. M. (2018). *The development of mental rotation abilities through robotics-based instruction: An experience mediated by gender*. *British Journal of Educational Technology*. Advance online publication.
<https://doi.org/10.1111/bjet.12726>

Jiménez Castro, M., Cerdas González, R. J: (2014). *La robótica educativa como agente promotor del estudio por la ciencia y la tecnología en la región atlántica de Costa Rica*. Art- 381.

Lopes, A., Lopes, F. y Guedes, M.C. (2016). *Experiencias de robótica educativa*. *Revista Internacional de Tecnología, Ciencia y Sociedad*, 4(2), 193-204.

Martínez, E., Escamilla, D. and Campos, A., (2019). *Industry 4.0 and the digital transformation. A new challenge for higher education*. *ECORFAN Journal-Republic of Paraguay*, 5(9), pp. 13-19.

Mercado-Bautista, J. (2020). *Evolución de los softwares de simulación para el diseño y construcción en la Industria*. *Polo del Conocimiento* 5 (48) , 1333-1343.

Niño J. y Fernández, F. (2019). *Una mirada a la enseñanza de conceptos científicos y tecnológicos a través de material didáctico utilizado*. *Revista Espacios*. 40(15), 4.

Restrepo-Echeverri, D., Branch-Bedoya, J.W. and Jiménez-Builes, J. (2022). *Educación 4.0: integración de robótica educativa y dispositivos móviles inteligentes como estrategia didáctica para la formación de ingenieros en STEM*. *DYNA*, 89(222), pp. 124-135, *Special engineering education*.
<https://www.redalyc.org/journal/496/49673349015/html/>

Sampieri, R., Fernández, C., and Batista, M. (2014). *Metodología de la Investigación* (Sexta Ed.). México D.F.

Martens, H. Hassani, S., Qannari, E.M., and Kohler, A., (2012) *Degrees of freedom estimation in Principal Component Analysis and Consensus Principal Component Analysis*, *Chemom. Intell. Lab. Syst.*, 118, 246-259.

Pérez, G. Niño, J. y Fernández, F. (2020). *Estrategia pedagógica basada en simuladores para potenciar las competencias de solución de problemas de física*. *Aibi, Revista de Investigación, Administración e Ingeniería*, 8(3), 17-23.
<https://doi.org/10.15649/2346030X.863>

Supports

Lopes, A., Lopes, F. y Guedes, M.C. (2016). [Experiencias de robótica educativa](#). *Revista Internacional de Tecnología, Ciencia y Sociedad*, 4(2), 193-204.

Mercado-Bautista, J. (2020). [Evolución de los softwares de simulación para el diseño y construcción en la Industria](#). *Polo del Conocimiento* 5 (48) , 1333-1343.

Niño J. y Fernández, F. (2019). [Una mirada a la enseñanza de conceptos científicos y tecnológicos a través de material didáctico utilizado](#). *Revista Espacios*. 40 (15), 4.

Yang, S. Zhong, Y. Feng, D. Yi Man Li, R. Shao, X. Liu, W. (2022) [Robot application and occupational injuries: Are robots necessarily safer?](#), *Safety Science*, (147) ISSN 0925-7535. <https://doi.org/10.1016/j.ssci.2021.105623>

Instructions for Scientific, Technological and Innovation Publications

[[Title in TNRoman and Bold No. 14 in English and Spanish]

Surname, Name 1st Author*^a, Surname, Name 1st Co-author^b, Surname, Name 2nd Co-author^c and Surname, Name 3rd Co-author^d [No.12 TNRoman]

^a  [Affiliation institution](#),  [Researcher ID](#),  [ORCID ID](#), [SNI-SECIHTI ID](#) or CVU PNPC [No.10 TNRoman]

^b  [Affiliation institution](#),  [Researcher ID](#),  [ORCID ID](#), [SNI-SECIHTI ID](#) or CVU PNPC [No.10 TNRoman]

^c  [Affiliation institution](#),  [Researcher ID](#),  [ORCID ID](#), [SNI-SECIHTI ID](#) or CVU PNPC [No.10 TNRoman]

^d  [Affiliation institution](#),  [Researcher ID](#),  [ORCID ID](#), [SNI-SECIHTI ID](#) or CVU PNPC [No.10 TNRoman]

All ROR-Clarivate-ORCID and SECIHTI profiles must be hyperlinked to your website.

Prot-  [University of South Australia](#) •  [7038-2013](#) •  [0000-0001-6442-4409](#) •  416112

SECIHTI classification:

https://marvid.org/research_areas.php [No.10 TNRoman]

Area:
Field:
Discipline:
Subdiscipline:

DOI: <https://doi.org/>

Article History:

Received: [Use Only ECORFAN]

Accepted: [Use Only ECORFAN]

Contact e-mail address:

*  [example@example.org]



Abstract [In English]

Must contain up to 150 words

Graphical abstract [In English]

Your title goes here		
Objectives	Methodology	Contribution

Authors must provide an original image that clearly represents the article described in the article. Graphical abstracts should be submitted as a separate file. Please note that, as well as each article must be unique. File type: the file types are MS Office files.No additional text, outline or synopsis should be included. Any text or captions must be part of the image file. Do not use unnecessary white space or a "graphic abstract" header within the image file.

Keywords [In English]

Indicate 3 keywords in TNRoman and Bold No. 10

Abstract [In Spanish]

Must contain up to 150 words

Graphical abstract [In Spanish]

Your title goes here		
Objectives	Methodology	Contribution

Authors must provide an original image that clearly represents the article described in the article. Graphical abstracts should be submitted as a separate file. Please note that, as well as each article must be unique. File type: the file types are MS Office files.No additional text, outline or synopsis should be included. Any text or captions must be part of the image file. Do not use unnecessary white space or a "graphic abstract" header within the image file.

Keywords [In Spanish]

Indicate 3 keywords in TNRoman and Bold No. 10

Citation: Surname, Name 1st Author, Surname, Name 1st Co-author, Surname, Name 2nd Co-author and Surname, Name 3rd Co-author. Article Title. Journal of Technological Development. Year. V-N: Pages [TN Roman No.10].



ISSN 2531-2960/© 2009 The Authors. Published by ECORFAN-México, S.C. for its Holding Spain on behalf of Journal of Technological Development. This is an open-access article under the license CC BY-NC-ND license [<http://creativecommons.org/licenses/by-nc-nd/4.0/>]

Peer review under the responsibility of the Scientific Committee MARVID® in the contribution to the scientific, technological and innovation Peer Review Process through the training of Human Resources for the continuity in the Critical Analysis of International Research.



Introduction

Text in TNRoman No.12, single space.

General explanation of the subject and explain why it is important.

What is your added value with respect to other techniques?

Clearly focus each of its features.

Clearly explain the problem to be solved and the central hypothesis.

Explanation of sections Article.

Development of headings and subheadings of the article with subsequent numbers

[Title No.12 in TNRoman, single spaced and bold]

Products in development No.12 TNRoman, single spaced.

Including figures and tables-Editable

In the article content any table and figure should be editable formats that can change size, type and number of letter, for the purposes of edition, these must be high quality, not pixelated and should be noticeable even reducing image scale.

[Indicating the title at the bottom with No.10 and Times New Roman Bold]

Box

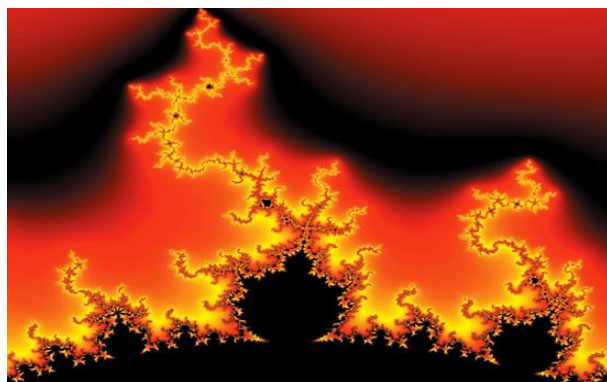

Figure 1

Title [Should not be images-everything must be editable]

Source [in italic]

Box

Table 1

Title [Should not be images-everything must be editable]

Source [in italic]

The maximum number of Boxes is 10 items

For the use of equations, noted as follows:

$$Y_{ij} = \alpha + \sum_{h=1}^r \beta_h X_{hij} + u_j + e_{ij} \quad [1]$$

Must be editable and number aligned on the right side.

Methodology

Develop give the meaning of the variables in linear writing and important is the comparison of the used criteria.

Results

The results shall be by section of the article.

Conclusions

Clearly explain the results and possibilities of improvement.

Annexes

Tables and adequate sources.

The international standard is 7 pages minimum and 14 pages maximum.

Declarations

Conflict of interest

The authors declare no interest conflict. They have no known competing financial interests or personal relationships that could have appeared to influence the article reported in this article.

Instructions for Scientific, Technological and Innovation Publications

Author contribution

Specify the contribution of each researcher in each of the points developed in this research.

Prot-
Benoit-Pauleter, Gerard: Contributed to the project idea, research method and technique.

Availability of data and materials

Indicate the availability of the data obtained in this research.

Funding

Indicate if the research received some financing.

Acknowledgements

Indicate if they were financed by any institution, University or company.

Abbreviations

List abbreviations in alphabetical order.

Prot-
ANN Artificial Neural Network

References

Use APA system. Should not be numbered, nor with bullets, however if necessary numbering will be because reference or mention is made somewhere in the Article.

Use the Roman alphabet, all references you have used should be in Roman alphabet, even if you have cited an article, book in any of the official languages of the United Nations [English, French, German, Chinese, Russian, Portuguese, Italian, Spanish, Arabic], you should write the reference in Roman alphabet and not in any of the official languages.

Citations are classified the following categories:

Antecedents. The citation is due to previously published research and orients the citing document within a particular scholarly area.

Basics. The citation is intended to report data sets, methods, concepts and ideas on which the authors of the citing document base their work.

Supports. The citing article reports similar results. It may also refer to similarities in methodology or, in some cases, to the reproduction of results.

Differences. The citing document reports by means of a citation that it has obtained different results to those obtained in the cited document. This may also refer to differences in methodology or differences in sample sizes that affect the results.

Discussions. The citing article cites another study because it is providing a more detailed discussion of the subject matter.

The URL of the resource is activated in the DOI or in the title of the resource.

Prot-
Mandelbrot, B. B. [2020]. [Negative dimensions and Hölders, multifractals and their Hölder spectra, and the role of lateral preasymptotics in science](#). Journal of Fourier Analysis and Applications Special. 409-432.

Intellectual Property Requirements for editing:

- Authentic Signature in Color of [Originality Format](#) Author and Coauthors.
- Authentic Signature in Color of the [Acceptance Format](#) of Author and Coauthors.
- Authentic Signature in blue color of the [Conflict of Interest Format](#) of Author and Co-authors.

Reservation to Editorial Policy

Journal of Technological Development reserves the right to make editorial changes required to adapt the Articles to the Editorial Policy of the Research Journal. Once the Article is accepted in its final version, the Research Journal will send the author the proofs for review. ECORFAN® will only accept the correction of errata and errors or omissions arising from the editing process of the Research Journal, reserving in full the copyrights and content dissemination. No deletions, substitutions or additions that alter the formation of the Article will be accepted.

Code of Ethics - Good Practices and Declaration of Solution to Editorial Conflicts

Declaration of Originality and unpublished character of the Article, of Authors, on the obtaining of data and interpretation of results, Acknowledgments, Conflict of interests, Assignment of rights and Distribution

The ECORFAN-Mexico, S.C Management claims to Authors of Articles that its content must be original, unpublished and of Scientific, Technological and Innovation content to be submitted for evaluation.

The Authors signing the Article must be the same that have contributed to its conception, realization and development, as well as obtaining the data, interpreting the results, drafting and reviewing it. The Corresponding Author of the proposed Article will request the form that follows.

Article title:

- The sending of an Article to Journal of Technological Development emanates the commitment of the author not to submit it simultaneously to the consideration of other series publications for it must complement the Format of Originality for its Article, unless it is rejected by the Arbitration Committee, it may be withdrawn.
- None of the data presented in this article has been plagiarized or invented. The original data are clearly distinguished from those already published. And it is known of the test in PLAGSCAN if a level of plagiarism is detected Positive will not proceed to arbitrate.
- References are cited on which the information contained in the Article is based, as well as theories and data from other previously published Articles.
- The authors sign the Format of Authorization for their Article to be disseminated by means that ECORFAN-Mexico, S.C. In its Holding Spain considers pertinent for disclosure and diffusion of its Article its Rights of Work.
- Consent has been obtained from those who have contributed unpublished data obtained through verbal or written communication, and such communication and Authorship are adequately identified.
- The Author and Co-Authors who sign this work have participated in its planning, design and execution, as well as in the interpretation of the results. They also critically reviewed the paper, approved its final version and agreed with its publication.
- No signature responsible for the work has been omitted and the criteria of Scientific Authorization are satisfied.
- The results of this Article have been interpreted objectively. Any results contrary to the point of view of those who sign are exposed and discussed in the Article.

Copyright and Access

The publication of this Article supposes the transfer of the copyright to ECORFAN-Mexico, SC in its Holding Spain for its Journal of Technological Development, which reserves the right to distribute on the Web the published version of the Article and the making available of the Article in This format supposes for its Authors the fulfilment of what is established in the Law of Science and Technology of the United Mexican States, regarding the obligation to allow access to the results of Scientific Research.

Article Title:

Name and Surnames of the Contact Author and the Coauthors	Signature
1.	
2.	
3.	
4.	

Principles of Ethics and Declaration of Solution to Editorial Conflicts

Editor Responsibilities

The Publisher undertakes to guarantee the confidentiality of the evaluation process, it may not disclose to the Arbitrators the identity of the Authors, nor may it reveal the identity of the Arbitrators at any time.

The Editor assumes the responsibility to properly inform the Author of the stage of the editorial process in which the text is sent, as well as the resolutions of Double-Blind Review.

The Editor should evaluate manuscripts and their intellectual content without distinction of race, gender, sexual orientation, religious beliefs, ethnicity, nationality, or the political philosophy of the Authors.

The Editor and his editing team of ECORFAN® Holdings will not disclose any information about Articles submitted to anyone other than the corresponding Author.

The Editor should make fair and impartial decisions and ensure a fair Double-Blind Review.

Responsibilities of the Editorial Board

The description of the peer review processes is made known by the Editorial Board in order that the Authors know what the evaluation criteria are and will always be willing to justify any controversy in the evaluation process. In case of Plagiarism Detection to the Article the Committee notifies the Authors for Violation to the Right of Scientific, Technological and Innovation Authorization.

Responsibilities of the Arbitration Committee

The Arbitrators undertake to notify about any unethical conduct by the Authors and to indicate all the information that may be reason to reject the publication of the Articles. In addition, they must undertake to keep confidential information related to the Articles they evaluate.

Any manuscript received for your arbitration must be treated as confidential, should not be displayed or discussed with other experts, except with the permission of the Editor.

The Arbitrators must be conducted objectively, any personal criticism of the Author is inappropriate.

The Arbitrators must express their points of view with clarity and with valid arguments that contribute to the Scientific, Technological and Innovation of the Author.

The Arbitrators should not evaluate manuscripts in which they have conflicts of interest and have been notified to the Editor before submitting the Article for Double-Blind Review.

Responsibilities of the Authors

Authors must guarantee that their articles are the product of their original work and that the data has been obtained ethically.

Authors must ensure that they have not been previously published or that they are not considered in another serial publication.

Authors must strictly follow the rules for the publication of Defined Articles by the Editorial Board.

The authors have requested that the text in all its forms be an unethical editorial behavior and is unacceptable, consequently, any manuscript that incurs in plagiarism is eliminated and not considered for publication.

Authors should cite publications that have been influential in the nature of the Article submitted to arbitration.

Information services

Indexation - Bases and Repositories

LATINDEX (Scientific Journals of Latin America, Spain and Portugal)

EBSCO (Research Database - EBSCO Industries)

RESEARCH GATE (Germany)

GOOGLE SCHOLAR (Citation indices-Google)

MENDELEY (Bibliographic References Manager)

REDIB (Ibero-American Network of Innovation and Scientific Knowledge- CSIC)

HISPANA (Information and Bibliographic Orientation-Spain)

Publishing Services

Citation and Index Identification H

Management of Originality Format and Authorization

Testing Article with PLAGSCAN

Article Evaluation

Certificate of Double-Blind Review

Article Edition

Web layout

Indexing and Repository

Article Translation

Article Publication

Certificate of Article

Service Billing

Editorial Policy and Management

38 Matacerquillas, CP-28411. Moralarzal –Madrid-España. Phones: +52 1 55 6159 2296, +52 1 55 1260 0355, +52 1 55 6034 9181; Email: contact@ecorfan.org www.ecorfan.org

ECORFAN®

Chief Editor

Banerjee, Bidisha. PhD

Executive Director

Ramos-Escamilla, María. PhD

Editorial Director

Peralta-Castro, Enrique. MsC

Web Designer

Escamilla-Bouchan, Imelda. PhD

Web Diagrammer

Luna-Soto, Vladimir. PhD

Editorial Assistant

Soriano-Velasco, Jesús. BsC

Philologist

Ramos-Arancibia, Alejandra. BsC

Advertising & Sponsorship

(ECORFAN® Spain), sponsorships@ecorfan.org

Site Licences

03-2010-032610094200-01-For printed material ,03-2010-031613323600-01-For Electronic material,03-2010-032610105200-01-For Photographic material,03-2010-032610115700-14-For the facts Compilation,04-2010-031613323600-01-For its Web page,19502-For the Iberoamerican and Caribbean Indexation,20-281 HB9-For its indexation in Latin-American in Social Sciences and Humanities,671-For its indexing in Electronic Scientific Journals Spanish and Latin-America,7045008-For its divulgation and edition in the Ministry of Education and Culture-Spain,25409-For its repository in the Biblioteca Universitaria-Madrid,16258-For its indexing in the Dialnet,20589-For its indexing in the edited Journals in the countries of Iberian-America and the Caribbean, 15048-For the international registration of Congress and Colloquiums. financingprograms@ecorfan.org

Management Offices

38 Matacerquillas, CP-28411. Moralarzal –Madrid-España.

Journal of Technological Development

“Spatial and temporal variation of BTEX in Villahermosa, Tabasco, during the dry and rainy seasons of 2024”

Uc-Chi, Martha Patricia, Cerón-Bretón, Julia Griselda, Cerón-Bretón, Rosa María and Silis-Esquivel, Jhoanna

Universidad Autónoma del Carmen

“Metallic particulates in pulmonary tissue”

Peña-García, Laura Elizabeth

Universidad de Guadalajara

“Learning analytics with CAD traces and predictive models: Reliability and performance”

Corral-Verdugo, Alex, Sepúlveda-Romo, Adrián, Jimenez-Lopez, Eusebio and León-Rochin, German

Universidad Tecnológica del sur de Sonora

Instituto Tecnológico Superior de Cajeme

“Environmental impact of wastewater discharges containing surfactants and their effect on biomass in anaerobic reactors during treatment”

Terreros, Jesús, Velazquez, Gisela and Muriel, Frank

Universidad Tecnológica del Valle de Toluca

“Perception of electricity service quality and its impact on local development. Study in Jalpan de Serra, Querétaro”

Morado-Huerta, Ma Guadalupe, Márquez-Hernández, Olga, López-Hernández, Edgardo and Ibarra-Pérez, Juan

Universidad Tecnológica de San Juan del Río

“Design and selection of solid urban waste collection routes using mixed integer linear programming under a practical approach”

Velarde-Cantú, José Manuel, López-Acosta, Mauricio, Chacara-Montes, Allán and Ramírez-Cardenas, Ernesto

Instituto Tecnológico de Sonora

“Design and CAD modeling of the mechanical base of an anthropomorphic robot arm, integrating technical analysis, 2D/3D drawing, assembly and animation, for educational purposes”

Peña-Montes De Oca, Adriana Isela, Gallardo-De La Rocha, Alfonso and Hernández, Adriana Janette

Universidad Tecnológica de Jalisco

